

AlSensis™ - A0011 Touch ASIC Data Sheet

August 3, 2011 **"PRILIMINARY"**

Overview

The patented AlSensis A0011 Touch ASIC is a complete 1 – 6 input touch sensing solution. It includes all signal processing functions necessary to provide robust sensing under a wide variety of changing conditions. Only minimal, low cost components are required for standard operation.

The AlSensis touch sensing solution differentiates itself from competitive capacitive offerings by measuring the actual touch event signature versus relying on comparisons of measured signals to predetermined thresholds; providing a reliable solution to your touch application. By measuring the signature of a touch event in combination with AlSensis proprietary electrode geometries, potential interference from EMI, moisture and surface contaminants is eliminated. Another benefit of measuring the signature of the touch event is the ability to distinguish between a glove touch and a "bare finger" touch while giving the user the same feel of sensitivity.

Communication with the A0011 ASIC is provided via I2C protocol. Individual and multiple sensor scans can be requested as well as device status, and configuration.

The A0011 ASIC is very easy to integrate into products by reducing the amount up-front engineering normally required for implementing capacitive solutions which reduces your time to market and development costs.

Key Product Features

- Complete 1 – 6 Touch Sensor Solution
- Patented AlSensis Touch Sensing Technology
- I2C for host interface
- Wide electrode size and shape tolerance
- Electrode materials can be etched copper, printed silver, Indium Tin Oxide (ITO)
- Electrode substrates can be PCB, FPCB, PET, polyimide, polycarbonate, glass
- Touch surface fascia materials can be glass, plastic, composites, wood, leather, fabric, others
- Power: 3.3vdc or 5.0vdc
- Package: 14 Pin TSSOP (A0011T), 14 Pin SOIC (A0011S), 16 Pin QFN (A0011Q), 14 Pin PDIP (A0011P)

AI Senti s™ - A0011 Touch ASIC Data Sheet

August 3, 2011 "PRILIMINARY"

What is AI Senti s™ HSS™ Touch Technology?

AI Senti s™ HSS™ touch technology is a fundamental departure from other "touch sensing" technology systems. While still utilizing electric fields, **AI Senti s™ HSS™** touch systems do not rely on overcoming a capacitance threshold level, they simply look for your defined "touch signature" to determine a touch event has taken place. Because **AI Senti s™ HSS™** analyzes the "touch signature" (the actual touch event), the need for characterizing (or tuning) a system is virtually eliminated. Because you define your touch signature using **AI Senti s™ HSS™**, a single electrode can provide more information to your system, thus allowing you a multitude of input responses - ranging from a simple touch, to a gesture input, to a multiple input response - all from a single touch point. Multiple choices for input responses, but the **AI Senti s™ HSS™** touch definition eliminates an inadvertent actuation of the touch point. **AI Senti s™ HSS™** minimizes the need for software to determine if a touch event took place, and maximizes the opportunity to collect "touch signature" input that can be used to create additional "personalized" functionality. Put it all together ... and it is clear that a game changer has entered the touch sensing market. **AI Senti s™ HSS™** touch technology systems will maximize the number of unique solutions your product development team can provide for your customers. Contact our design team to discuss how **AI Senti s™ HSS™** touch technology systems can bring the "touch signature" advantage to your new products. For more information on **AI Senti s™** touch sensing technologies visit our website at www.AISentis.com.

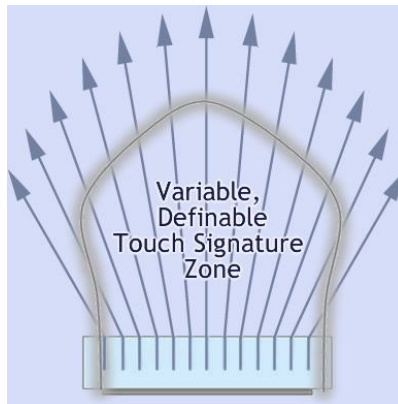

AlSentis™ - A0011 Touch ASIC Data Sheet

August 3, 2011 "PRILIMINARY"

Applications

➤ Consumer

- TV's
- Computers
- Copiers
- DVD Players
- Printers
- Control Panels
- Embedded Seating Controls
- Remote Controls
- Lighting Control

➤ Commercial

- Appliance/White Goods
- Office Furniture (Lighting Control, Access Control)
- Security Access Panels
- Lighting Control
- Control Panels

➤ Industrial

- Control Panels
- Mechanical/Optical Button Replacement
- Instrumentation

➤ Automotive

- Interior Controls
 - Center Stack
 - Steering Wheel Control
 - Mirror
- Exterior Control (requires integrated PAD and system design)

➤ Medical

- Patient Room
- Instrumentation

AlSentis™ - A0011 Touch ASIC Data Sheet

August 3, 2011 "PRILIMINARY"

Device Specifications

Operating Temperature	-40°C ≤ TA ≤ +85°C or 105°C
Supply Voltage (Vdd)	2.5Vdc – 5.5Vdc
Supply Current (Idd)	2.0ma Wake, 65µa Sleep (5Vdc), 48µa (3.3Vdc)
Max Touch Response	<40ms
Max Touch Response (from sleep)	<70ms
# of Touch Inputs	1-6
Touch Input Device	14mm Pad – 2mm Plastic, 3mm Glass
Input ESD resistor	10K Ohm (Required external)
Communications	I2C Slave

I2C Communications Summary

The following functions are available via the I2C protocol

Select # of Touch Inputs (Configuration)
Set Slave address
Read individual Button Status
Read Group button Status
Read Device Status
Place Device in Sleep mode
Wake Device
Software Reset

AlSentis™ - A0011 Touch ASIC Data Sheet

August 3, 2011 "PRILIMINARY"

14 Pin Diagram For X0011

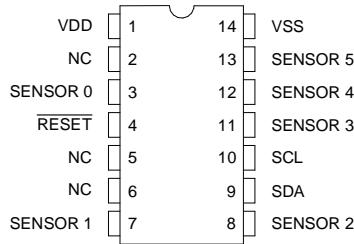

Pin Descriptions

Pin Number	Name	Type	Description/Connection
1	VDD	Power	Positive Power Pin
2	NC	No Connection	Unused pin – Do Not Connect
3	Sensor 0	Touch Sensor Input	Connect To Sensor 0 Electrode
4	Reset	Input	Allows for Manual Reset of ASIC (See Application Example for Specific Details)
5	NC	No Connection	Unused pin – Do Not Connect
6	NC	No Connection	Unused pin – Do Not Connect
7	Sensor 1	Touch Sensor Input	Connect To Sensor 1 Electrode
8	Sensor 2	Touch Sensor Input	Connect To Sensor 2 Electrode
9	SDA	Communication	I2C Data Bus
10	SCL	Communication	I2C Clock Bus
11	Sensor 3	Touch Sensor Input	Connect To Sensor 3 Electrode
12	Sensor 4	Touch Sensor Input	Connect To Sensor 4 Electrode
13	Sensor 5	Touch Sensor Input	Connect To Sensor 5 Electrode
14	VSS	Power	Ground Power Pin

AI Sentis™ - A0011 Touch ASIC Data Sheet

August 3, 2011 "PRILIMINARY"

16 Pin Diagram For X0011

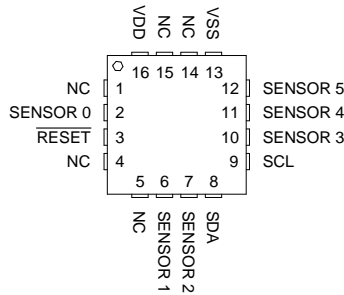

Pin Descriptions

Pin Number	Name	Type	Description/Connection
1	NC	No Connection	Unused pin – Do Not Connect
2	SENSOR 0	Touch Sensor Input	Connect To Sensor 0 Electrode
3	RESET	Input	Allows for Manual Reset of ASIC (See Application Example for Specific Details)
4	NC	No Connection	Unused pin – Do Not Connect
5	NC	No Connection	Unused pin – Do Not Connect
6	SENSOR 1	Touch Sensor Input	Connect To Sensor 1 Electrode
7	SENSOR 2	Touch Sensor Input	Connect To Sensor 2 Electrode
8	SDA	Communication	I2C Data Bus
9	SCL	Communication	I2C Clock Bus
10	SENSOR 3	Touch Sensor Input	Connect To Sensor 3 Electrode
11	SENSOR 4	Touch Sensor Input	Connect To Sensor 4 Electrode
12	SENSOR 5	Touch Sensor Input	Connect To Sensor 5 Electrode
13	VSS	Power	Ground Power Pin
14	NC	No Connection	Unused pin – Do Not Connect
15	NC	No Connection	Unused pin – Do Not Connect
16	VDD	Power	Positive Power Pin

AI Sentis™ - A0011 Touch ASIC Data Sheet

August 3, 2011 "PRILIMINARY"

Packaging Information:

- 14 Pin TSSOP
- 16 Pin QFN
- 14 Pin SOIC
- 14 Pin PDIP

Typical 14-Lead Plastic Thin Shrink Small Outline – 4.4 mm Body [TSSOP]

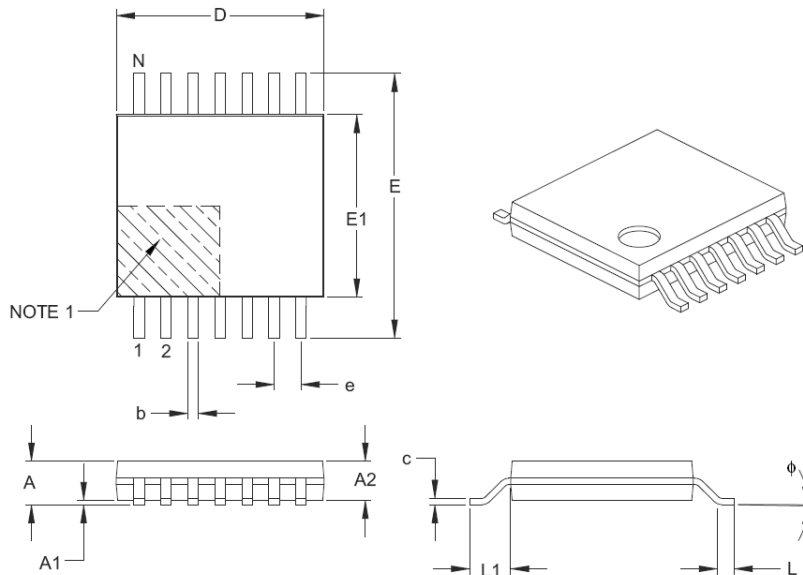

Dimension Limits	Units	MILLIMETERS		
		MIN	NOM	MAX
Number of Pins	N	14		
Pitch	e	0.65 BSC		
Overall Height	A	–	–	1.20
Molded Package Thickness	A2	0.80	1.00	1.05
Standoff	A1	0.05	–	0.15
Overall Width	E	6.40 BSC		
Molded Package Width	E1	4.30	4.40	4.50
Molded Package Length	D	4.90	5.00	5.10
Foot Length	L	0.45	0.60	0.75
Footprint	L1	1.00 REF		
Foot Angle	φ	0°	–	8°
Lead Thickness	c	0.09	–	0.20
Lead Width	b	0.19	–	0.30

Notes:

- Pin 1 visual index feature may vary, but must be located within the hatched area.
- Dimensions D and E1 do not include mold flash or protrusions. Mold flash or protrusions shall not exceed 0.15 mm per side.
- Dimensioning and tolerancing per ASME Y14.5M.
BSC: Basic Dimension. Theoretically exact value shown without tolerances.
REF: Reference Dimension, usually without tolerance, for information purposes only.

AlSentis™ - A0011 Touch ASIC Data Sheet

August 3, 2011 "PRILIMINARY"

Typical 14-Lead Plastic Thin Shrink Small Outline – 4.4 mm Body [TSSOP]

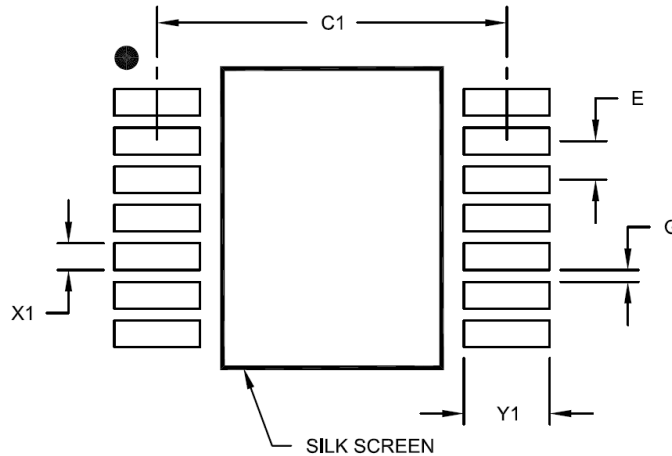

RECOMMENDED LAND PATTERN

Dimension Limits	Units	MILLIMETERS		
		MIN	NOM	MAX
Contact Pitch	E	0.65 BSC		
Contact Pad Spacing	C1		5.90	
Contact Pad Width (X28)	X1			0.45
Contact Pad Length (X28)	Y1			1.45
Distance Between Pads	G	0.20		

Notes:

1. Dimensioning and tolerancing per ASME Y14.5M

BSC: Basic Dimension. Theoretically exact value shown without tolerances.

AlSentis™ - A0011 Touch ASIC Data Sheet

August 3, 2011 "PRILIMINARY"

Typical 16-Lead Plastic Quad Flat, No Lead Package – 4x4x0.9 mm Body [QFN]

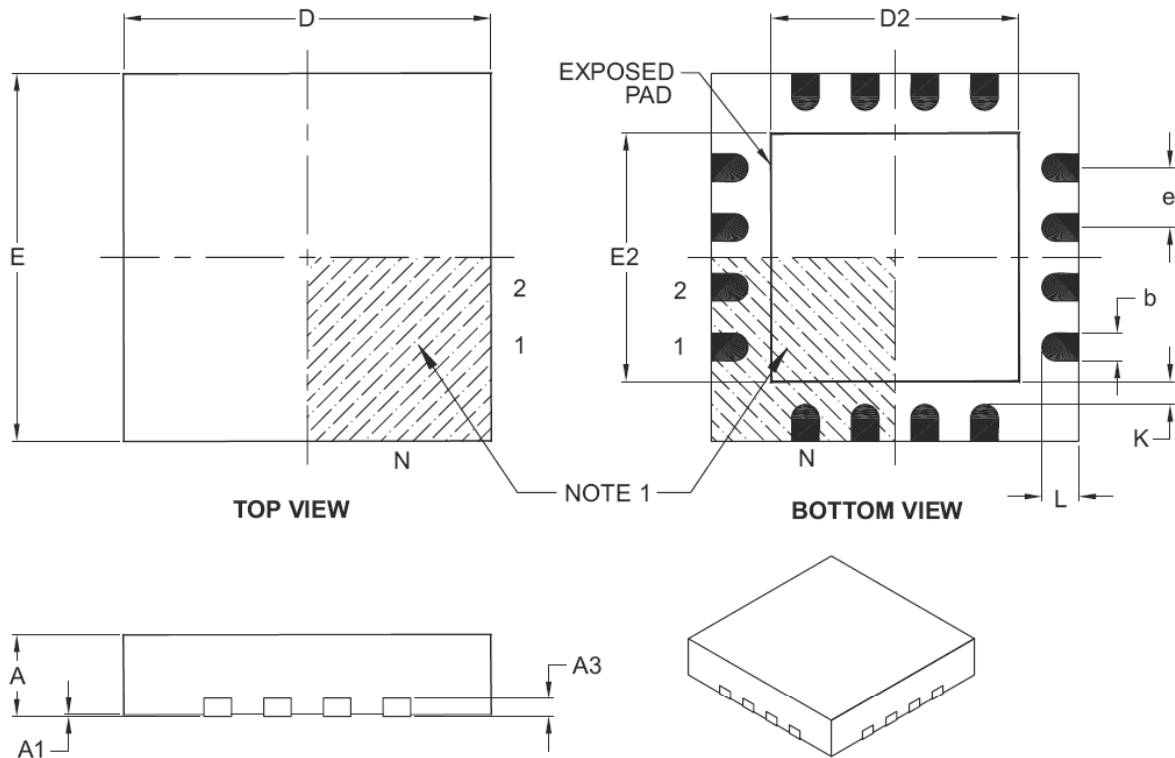

Dimension Limits	Units	MILLIMETERS		
		MIN	NOM	MAX
Number of Pins	N	16		
Pitch	e	0.65 BSC		
Overall Height	A	0.80	0.90	1.00
Standoff	A1	0.00	0.02	0.05
Contact Thickness	A3	0.20 REF		
Overall Width	E	4.00 BSC		
Exposed Pad Width	E2	2.50	2.65	2.80
Overall Length	D	4.00 BSC		
Exposed Pad Length	D2	2.50	2.65	2.80
Contact Width	b	0.25	0.30	0.35
Contact Length	L	0.30	0.40	0.50
Contact-to-Exposed Pad	K	0.20	-	-

Notes:

- Pin 1 visual index feature may vary, but must be located within the hatched area.
- Package is saw singulated.
- Dimensioning and tolerancing per ASME Y14.5M.

BSC: Basic Dimension. Theoretically exact value shown without tolerances.

REF: Reference Dimension, usually without tolerance, for information purposes only.

AlSentis™ - A0011 Touch ASIC Data Sheet

August 3, 2011 "PRILIMINARY"

Typical 16-Lead Plastic Quad Flat, No Lead Package – 4x4x0.9 mm Body [QFN]

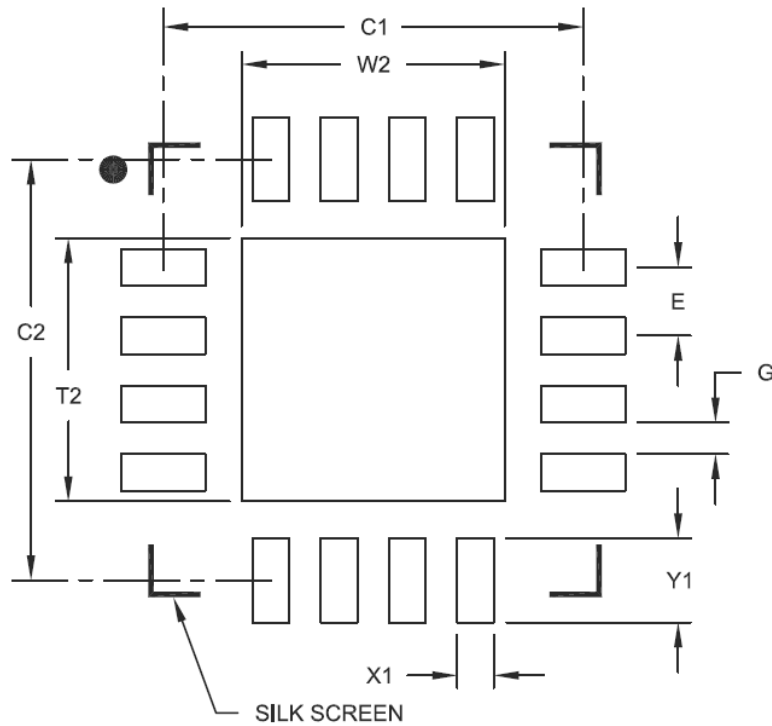

RECOMMENDED LAND PATTERN

Dimension Limits	Units	MILLIMETERS		
		MIN	NOM	MAX
Contact Pitch	E	0.65 BSC		
Optional Center Pad Width	W2			2.50
Optional Center Pad Length	T2			2.50
Contact Pad Spacing	C1		4.00	
Contact Pad Spacing	C2		4.00	
Contact Pad Width (X28)	X1			0.35
Contact Pad Length (X28)	Y1			0.80
Distance Between Pads	G	0.30		

Notes:

1. Dimensioning and tolerancing per ASME Y14.5M

BSC: Basic Dimension. Theoretically exact value shown without tolerances.

AlSentis™ - A0011 Touch ASIC Data Sheet

August 3, 2011 "PRILIMINARY"

Typical 14-Lead Plastic Small Outline – Narrow, 3.90 mm Body [SOIC]

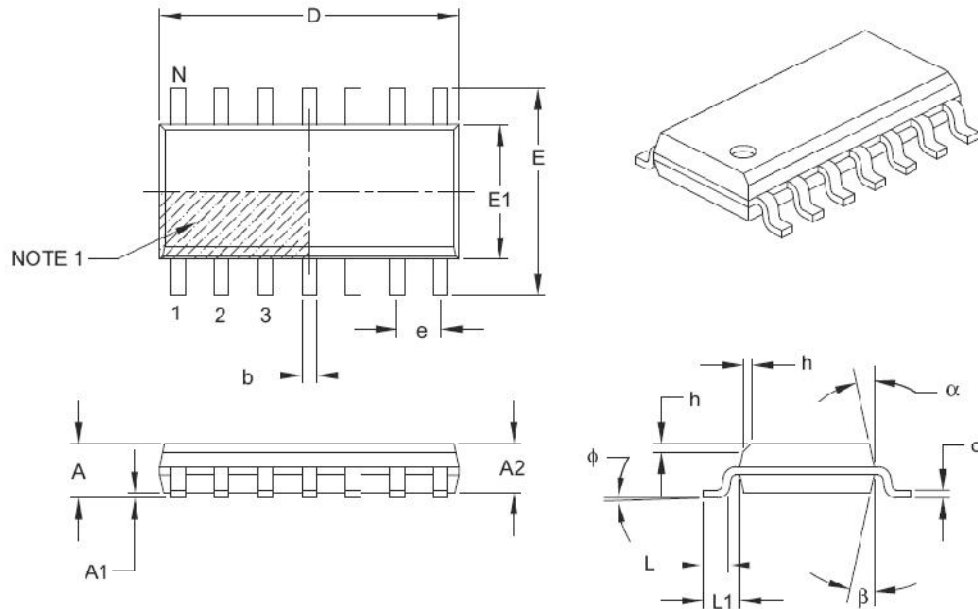

Dimension Limits	Units	MILLIMETERS		
		MIN	NOM	MAX
Number of Pins	N	14		
Pitch	e	1.27 BSC		
Overall Height	A	–	–	1.75
Molded Package Thickness	A2	1.25	–	–
Standoff §	A1	0.10	–	0.25
Overall Width	E	6.00 BSC		
Molded Package Width	E1	3.90 BSC		
Overall Length	D	8.65 BSC		
Chamfer (optional)	h	0.25	–	0.50
Foot Length	L	0.40	–	1.27
Footprint	L1	1.04 REF		
Foot Angle	φ	0°	–	8°
Lead Thickness	c	0.17	–	0.25
Lead Width	b	0.31	–	0.51
Mold Draft Angle Top	α	5°	–	15°
Mold Draft Angle Bottom	β	5°	–	15°

Notes:

- Pin 1 visual index feature may vary, but must be located within the hatched area.
- § Significant Characteristic.
- Dimensions D and E1 do not include mold flash or protrusions. Mold flash or protrusions shall not exceed 0.15 mm per side.
- Dimensioning and tolerancing per ASME Y14.5M.

BSC: Basic Dimension. Theoretically exact value shown without tolerances.

REF: Reference Dimension, usually without tolerance, for information purposes only.

AlSentis™ - A0011 Touch ASIC Data Sheet

August 3, 2011 "PRILIMINARY"

Typical 14-Lead Plastic Small Outline – Narrow, 3.90 mm Body [SOIC]

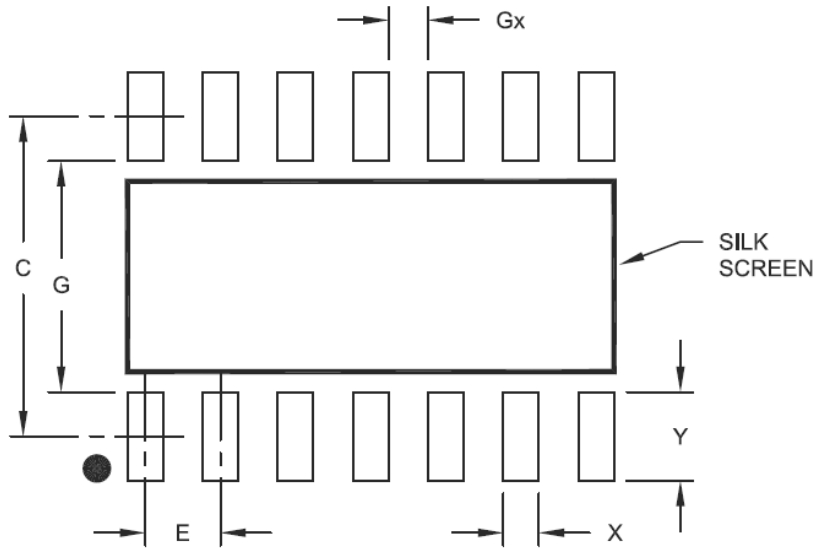

RECOMMENDED LAND PATTERN

Dimension Limits	Units	MILLIMETERS		
		MIN	NOM	MAX
Contact Pitch	E	1.27 BSC		
Contact Pad Spacing	C		5.40	
Contact Pad Width	X			0.60
Contact Pad Length	Y			1.50
Distance Between Pads	Gx	0.67		
Distance Between Pads	G	3.90		

Notes:

1. Dimensioning and tolerancing per ASME Y14.5M

BSC: Basic Dimension. Theoretically exact value shown without tolerances.

AlSentis™ - A0011 Touch ASIC Data Sheet

August 3, 2011 "PRILIMINARY"

Typical 14-Lead Plastic Dual In-Line – 300 mil Body [PDIP]

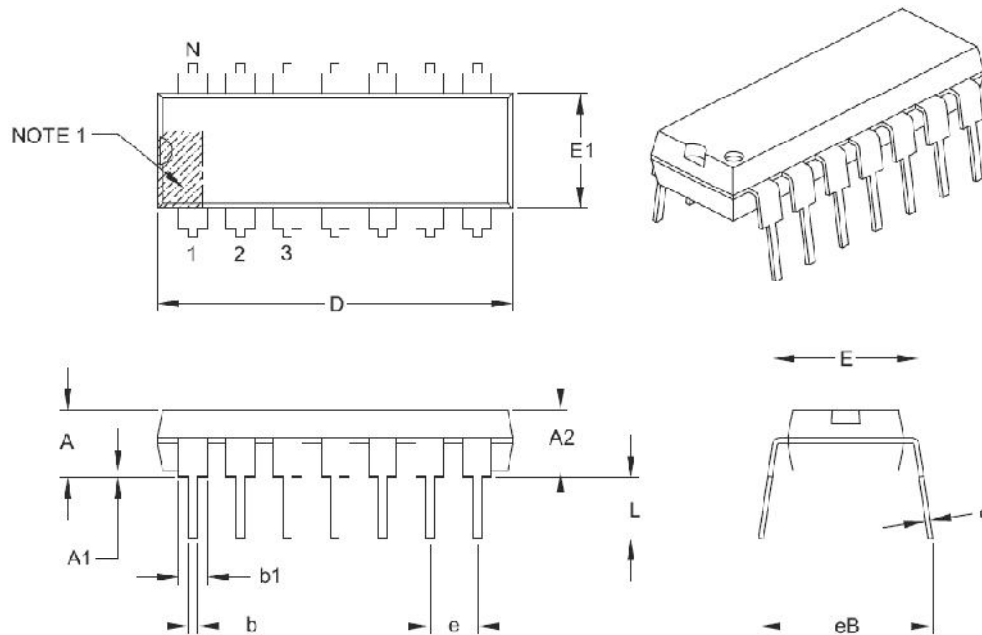

Dimension	Units			
	Dimension	MIN	NOM	MAX
Number of Pins	N	14		
Pitch	e	.100 BSC		
Top to Seating Plane	A	–	–	.210
Molded Package Thickness	A2	.115	.130	.195
Base to Seating Plane	A1	.015	–	–
Shoulder to Shoulder Width	E	.290	.310	.325
Molded Package Width	E1	.240	.250	.280
Overall Length	D	.735	.750	.775
Tip to Seating Plane	L	.115	.130	.150
Lead Thickness	c	.008	.010	.015
Upper Lead Width	b1	.045	.060	.070
Lower Lead Width	b	.014	.018	.022
Overall Row Spacing §	eB	–	–	.430

Notes:

1. Pin 1 visual index feature may vary, but must be located with the hatched area.
2. § Significant Characteristic.
3. Dimensions D and E1 do not include mold flash or protrusions. Mold flash or protrusions shall not exceed .010" per side.
4. Dimensioning and tolerancing per ASME Y14.5M.
BSC: Basic Dimension. Theoretically exact value shown without tolerances.

AlSensis™ - A0011 Touch ASIC Data Sheet

August 3, 2011 "PRILIMINARY"

Example A0011 Schematic

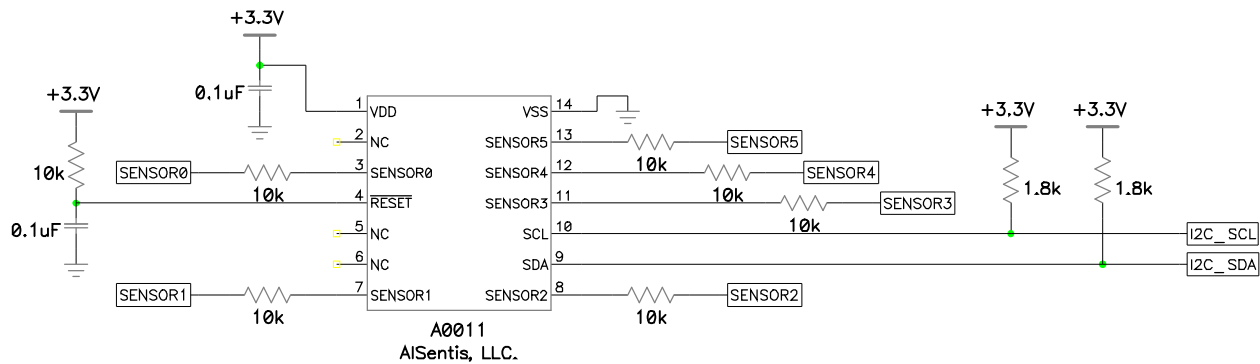

Ordering Information

Part Number Format = A0011XYZ

X ---- Application A = Automotive, C = Consumer/Industrial

Y ---- Temperature Range 1 = -40°C <= TA <= +85°C, 2 = -40°C <= TA <= 105°C

Z ---- Packaging Q = 16 Pin OFN, I = 14 Pin TSSOP, S = 14 Pin SOIC, P = 14 Pin PDIP