

Overview

The patented AlSensis® HSS™ Touch IC will provide a robust 1 – 15 input touch sensing solution. The Touch IC includes all signal processing functions necessary to provide robust sensing under a wide variety of changing conditions. Only minimal, low cost components are required for standard operation.

The AlSensis® HSS™ touch sensing solution differentiates itself from capacitance sensors by measuring the touch event using touch signatures versus relying on comparisons of measured signals to pre-determined thresholds. AlSensis® HSS™ signature based sensing provides a reliable solution for your touch applications. By measuring the signature of a touch event in combinations with AlSensis® HSS™ proprietary electrodes and circuitry, high levels of immunity to EMI, operation in the presence of water and washing solutions, same quality of touch feel with a bare and a gloved finger, same quality of touch feel with manufacturing and environmental variability, and fast response, can all be achieved simultaneously.

Communication with the AlSensis® HSS™ Touch IC is provided via I²C protocol. The Touch IC can be optimized by downloading a configuration file for the specific application, including which sensors are enabled and disabled and associated TRZ (Touch Recognition Zone). Updates of touch status can be accomplished by polling or by the generation of an interrupt from the Touch IC.

A Hibernate Mode is included in the AlSensis® HSS™ Touch IC for use in designs where it is desirable to disable the IC and reduce system quiescent current. The Hibernate Mode is enabled/disabled via the “Write Power Mode” I2C command. While in the Hibernate Mode, all IC functions are disabled.

The AlSensis® HSS™ Touch IC is very easy to integrate into products by reducing the amount of up-front engineering required for implementing capacitive solutions which reduces your time to market and development costs.

Features

- 1 – 15 input solution
- Patented HSS™ technology which inherently overcomes manufacturing and environmental variances
- Highly noise immune and robust operation in end application - passes IEC 61000-4-6:2008-10 (0.15-80MHz at 10vrms, 1KHz 80%AM), standing water and glove operation with 2mm plastic as demonstrated in AMDK0003A Development Kit
- I²C Output Communication
- Electrodes can be designed with etched copper, printed silver, ITO (Indium Tin Oxide), PEDOT, AgNW (silver nanowire), CNT (carbon nanotubes), and more
- Electrode substrates can be PCB, Flex PCB, PET, polyimide, polycarbonate, glass, and more
- Touch surface substrates can be glass, plastic, composites, wood, leather, fabric, and other non-conductive materials
- Enables the use of in-molding manufacturing techniques by overcoming inherent process variations

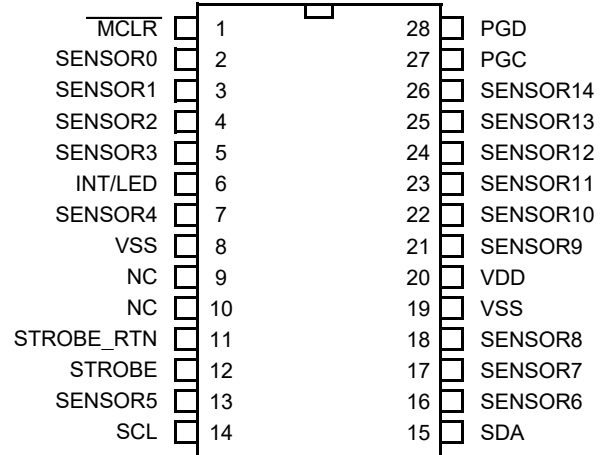

28 PIN SSOP or SOIC Package

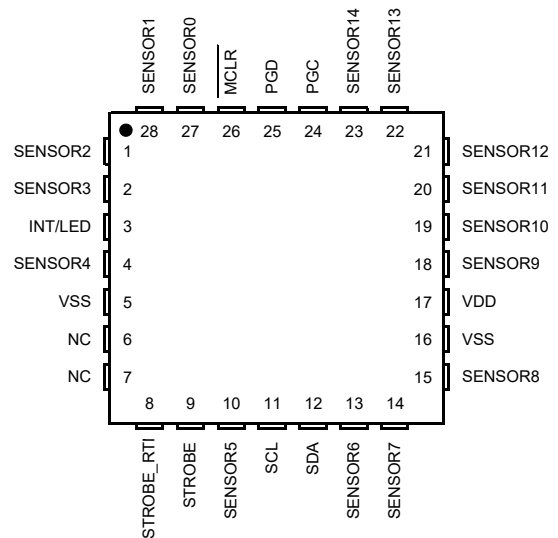

28 Pin QFN or UQFN Package

Ordering Information

Part Number Format: A0009XYZ

X (Packaging): **Q** = 28Pin QFN, **U** = 28Pin UQFN, **R** = 28Pin SSOP, **S** = 28Pin SOIC

Y (Temperature Range): **I** = -40C — +85C, **E** = -40C — 125C

Z (Grade): **A** = Automotive, **C** = Consumer

Electrical Characteristics

Absolute Maximum Ratings*

Designation	Item	Condition	Rated Value	Unit
T _{amb}	Ambient Temperature	Under Bias	-40 — +125	°C
T _{stg}	Storage Temperature		-65 — +150	°C
V _{dd}	Supply Voltage	Voltage on V _{dd} with respect to V _{ss}	-0.3 — +6.5	V
I _{INT}	IRQ Line Current	Sourcing	25	mA

* Exceeding the absolute maximum ratings may result in permanent damage to the device

Operating Conditions

Designation	Item	Condition	Rated Value			Unit
			Min	Nominal ⁽¹⁾	Max	
Supply Voltage = 5.0Vdc						
V _{dd}	Supply Voltage	+/-5%	4.75	5.0	5.25	V
I _{dd}	Supply Current (Normal Mode)		-	6.8	9.5	mA
I _{dd}	Supply Current (Hibernate Mode)		-	16	-	µA
V _{rl}	Reset Low Voltage	0.2*V _{dd}	-	-	1.0	V
V _{rh}	Reset High Voltage	0.8*V _{dd}	3.8	-	-	V
INT _h	IRQ High Voltage	0.8*V _{dd}	3.8	-	-	V
Supply Voltage = 3.3Vdc						
V _{dd}	Supply Voltage	+/-5%	3.14	3.30	3.46	V
I _{dd}	Supply Current (Normal mode)		-	6.2	8.5	mA
I _{dd}	Supply Current (Hibernate Mode)		-	16	-	µA
V _{rl}	Reset Low Voltage	0.2*V _{dd}	-	-	0.660	V
V _{rh}	Reset High Voltage	0.8*V _{dd}	2.64	-	-	V
INT _h	IRQ High Voltage	0.8*V _{dd}	2.64	-	-	V
Common						
T _{amb}	Ambient Temperature	Extended Temp Range	-40	-	+125	°C
T _{amb}	Ambient Temperature	Industrial Temp Range	-40	-	+85	°C
T _{rst}	Reset Low Pulse Width Timing		2	-	-	ms
T _{startup}	Time Before IC Is Ready	First Time Power Up	40	70	140	ms
T _{response}	True Touch Response Time		-	(LO+1)(PI) ⁽²⁾	-	ms
T _{switch}	Switching Time Between Power Modes		1	3	-	ms
T _{init}	Power Mode Initialization Time		-	3(PI) ⁽²⁾	-	ms

Notes: 1. Data in 'Nominal' column is at 25C
2. LO: Level Off Min, PI: Process Interval

28 PIN SSOP or SOIC Diagram

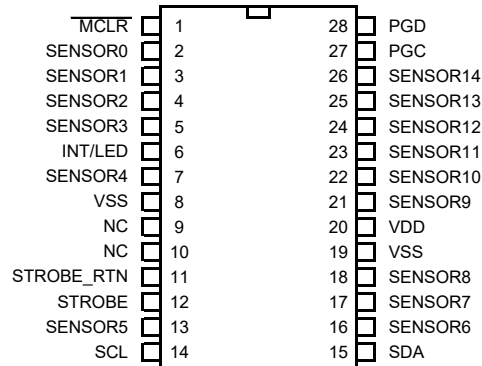

Pin	Name	Function	Description / Connection
1	MCLR	Input	Allows for manual reset of ASIC ⁽²⁾
2	SENSOR 0	Touch Sensor Input	Connect to Sensor 0 Electrode ⁽¹⁾
3	SENSOR 1	Touch Sensor Input	Connect to Sensor 1 Electrode ⁽¹⁾
4	SENSOR 2	Touch Sensor Input	Connect to Sensor 2 Electrode ⁽¹⁾
5	SENSOR 3	Touch Sensor Input	Connect to Sensor 3 Electrode ⁽¹⁾
6	INT/LED	Output	Data Ready Signal Line ⁽²⁾
7	SENSOR 4	Touch Sensor Input	Connect to Sensor 4 Electrode ⁽¹⁾
8	VSS	Power	Ground Connection
9	NC		Unused Pin—Do Not Connect
10	NC		Unused Pin—Do Not Connect
11	STROBE_RTN	Digital Input	Connect To Strobe Pin
12	STROBE	Output	Strobe Signal Output
13	SENSOR 5	Touch Sensor Input	Connect to Sensor 5 Electrode ⁽¹⁾
14	SCL	Communication	I ² C Clock Bus
15	SDA	Communication	I ² C Data Bus
16	SENSOR 6	Touch Sensor Input	Connect to Sensor 6 Electrode ⁽¹⁾
17	SENSOR 7	Touch Sensor Input	Connect to Sensor 7 Electrode ⁽¹⁾
18	SENSOR 8	Touch Sensor Input	Connect to Sensor 8 Electrode ⁽¹⁾
19	VSS	Power	Ground Connection
20	VDD	Power	Supply Voltage Connection
21	SENSOR 9	Touch Sensor Input	Connect to Sensor 9 Electrode ⁽¹⁾
22	SENSOR 10	Touch Sensor Input	Connect to Sensor 10 Electrode ⁽¹⁾
23	SENSOR 11	Touch Sensor Input	Connect to Sensor 11 Electrode ⁽¹⁾
24	SENSOR 12	Touch Sensor Input	Connect to Sensor 12 Electrode ⁽¹⁾
25	SENSOR 13	Touch Sensor Input	Connect to Sensor 13 Electrode ⁽¹⁾
26	SENSOR 14	Touch Sensor Input	Connect to Sensor 14 Electrode ⁽¹⁾
27	PGC	Communication	IC Programming Clock Bus
28	PGD	Communication	IC Programming Data Bus

Notes: 1. Sensor pins must be connected to active component block of the designated electrode or, if unused, must be connected to VSS (see AlSentis Reference Development Kit for specific details)
 2. See AlSentis Reference Development Kit for specific details

28 Pin QFN or UQFN Diagram

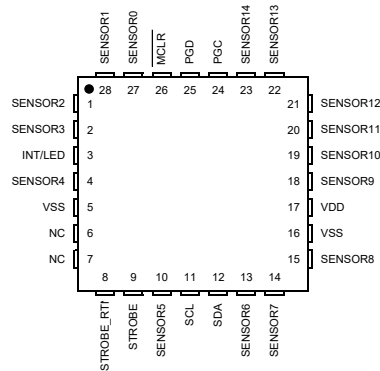

Pin	Name	Function	Description / Connection
1	SENSOR 2	Touch Sensor Input	Connect to Sensor 2 Electrode ⁽¹⁾
2	SENSOR 3	Touch Sensor Input	Connect to Sensor 3 Electrode ⁽¹⁾
3	INT/LED	Output	Data Ready Signal Line ⁽²⁾
4	SENSOR 4	Touch Sensor Input	Connect to Sensor 4 Electrode ⁽¹⁾
5	VSS	Power	Ground Connection
6	NC		Unused Pin—Do Not Connect
7	NC		Unused Pin—Do Not Connect
8	STROBE_RTN	Digital Input	Connect To Strobe Pin
9	STROBE	Output	Strobe Signal Output
10	SENSOR 5	Touch Sensor Input	Connect to Sensor 5 Electrode ⁽¹⁾
11	SCL	Communication	I ² C Clock Bus
12	SDA	Communication	I ² C Data Bus
13	SENSOR 6	Touch Sensor Input	Connect to Sensor 6 Electrode ⁽¹⁾
14	SENSOR 7	Touch Sensor Input	Connect to Sensor 7 Electrode ⁽¹⁾
15	SENSOR 8	Touch Sensor Input	Connect to Sensor 8 Electrode ⁽¹⁾
16	VSS	Power	Ground Connection
17	VDD	Power	Supply Voltage Connection
18	SENSOR 9	Touch Sensor Input	Connect to Sensor 9 Electrode ⁽¹⁾
19	SENSOR 10	Touch Sensor Input	Connect to Sensor 10 Electrode ⁽¹⁾
20	SENSOR 11	Touch Sensor Input	Connect to Sensor 11 Electrode ⁽¹⁾
21	SENSOR 12	Touch Sensor Input	Connect to Sensor 12 Electrode ⁽¹⁾
22	SENSOR 13	Touch Sensor Input	Connect to Sensor 13 Electrode ⁽¹⁾
23	SENSOR 14	Touch Sensor Input	Connect to Sensor 14 Electrode ⁽¹⁾
24	PGC	Communication	IC Programming Clock Bus
25	PGD	Communication	IC Programming Data Bus
26	MCLR	Input	Allows for manual reset of ASIC ⁽²⁾
27	SENSOR 0	Touch Sensor Input	Connect to Sensor 0 Electrode ⁽¹⁾
28	SENSOR 1	Touch Sensor Input	Connect to Sensor 1 Electrode ⁽¹⁾

Notes: 1. Sensor pins must be connected to active component block of the designated electrode or, if unused, must be connected to VSS (see AlSentis Reference Development Kit for specific details)

2. See AlSentis Reference Development Kit for specific details

Application Information

Block Diagram

Passive Single Electrode Version

Figure 1 shows a block diagram highlighting the connections for a standard Passive Electrode design. The electrodes are connected to the HSS IC through active circuitry which is described in detail within ALSentis Reference Development Kits. Place the active components as close to the input connector as possible. Communication to the HSS IC is accomplished through a standard master slave I²C protocol. Use of the INT line allows for interrupt enabled communications upon touch state changes.

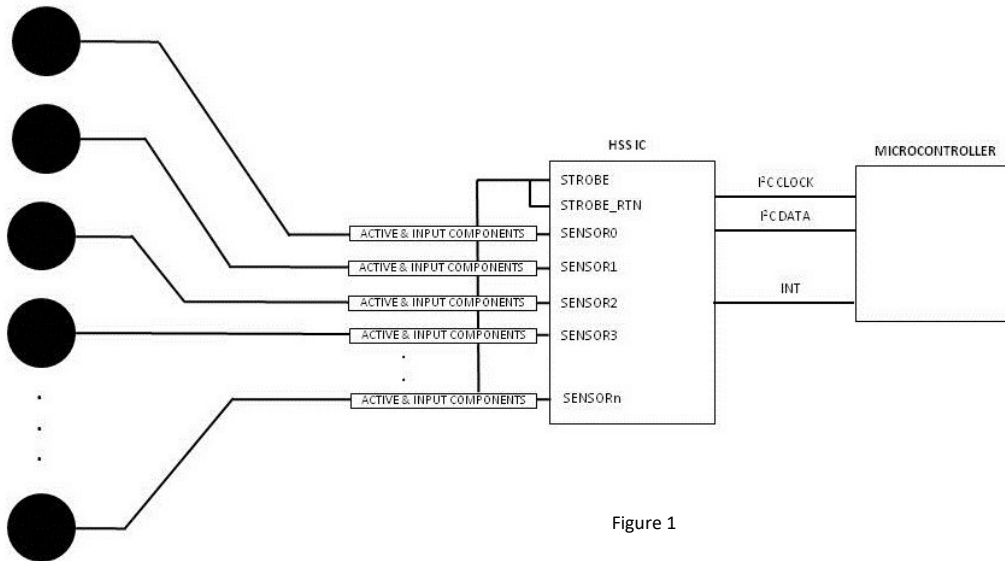

Figure 1

Active Dual Electrode Version

Figure 2 shows a block diagram highlighting the connections for a standard Active Electrode design. An Active Electrode design is typically employed to increase the overall robustness as compared to a Passive Electrode design. The electrodes along with a surrounding strobe ring are connected to the HSS IC through active circuitry that is described in detail within ALSentis Reference Development Kits. Place the active components as close to the electrodes as possible. Communication to the HSS IC is accomplished through a standard master slave I²C protocol. Use of the INT line allows for interrupt enabled communications upon touch state changes.

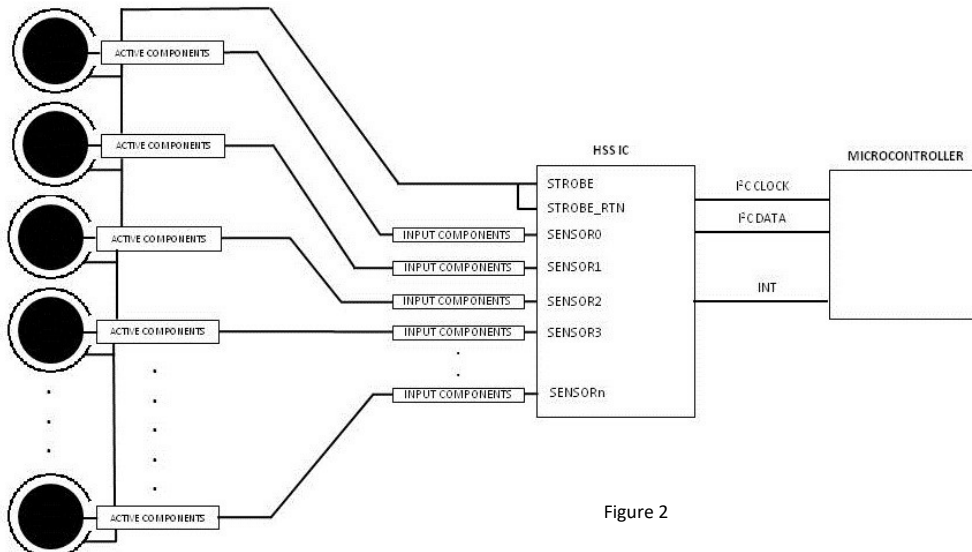

Figure 2

I2C Communications

The AlSensis® HSS Touch IC is communicated with exclusively through I2C. To ensure proper setup of the device, it is recommended that the device configuration be designed and tested using AlSensis HSS Touch Studio. Once the configuration is finalized, these commands can be used to control the device from a microcontroller. Unless otherwise stated, the default I2C address for the HSS Touch IC is 0xB0 with operation in slave mode only.

Clock Stretching

The AlSensis® HSS Touch IC utilizes bit stretching, giving priority to the HSS signature recognition.

Command Definitions Key

S	Start Condition
RS	Re-Start Condition
A/N	Acknowledge/Not Acknowledge
	Master Data Out
	Slave Data Out
P	Stop Condition

Command Set

The HSS Touch IC is configured using the 29 commands shown in the table below.

Command	Name
0x0A	Write Enabled Sensors
0x0E	Write TRZ
0x16	Write DVI Mode
0x1E	Clear Device Errors
0x52	Reset Device
0x0C	Write Latch-up Timeout
0x41	Write Process Interval
0x43	Write Number of Sample Sets
0x44	Write Pulse Configuration
0x40	Write Power Mode
0x45	Write HSS Signature Configuration 1
0x46	Write HSS Signature Configuration 2
0x48	Write Sleep Time
0x4A	Write IRQ Enable
0x4B	Write I2C Address
0x81	Read Device ID
0x8A	Read Enabled Sensors
0x8E	Read TRZ
0x9E	Read Device Status
0x9F	Read All Sensors
0x8C	Read Latch-up Timeout
0xC1	Read Process Interval
0xC3	Read Number of Sample Sets
0xC4	Read Pulse Configuration
0xC0	Read Power Mode
0xC5	Read HSS Signature Configuration 1
0xC6	Read HSS Signature Configuration 2
0xC7	Read DVI Value
0xC8	Read Sleep Time
0xCA	Read IRQ Enable

Write Enabled Sensors

Command Structure

Byte 1		
S	0xB0 (Address)	A/N
Byte 2		
	0x0A (Command)	A/N
Byte 3		
	Bitwise Sensor Select	A/N
Byte 4		
	Write Checksum	A/N
		P

Command Description

This command will tell the device which sensors to monitor. The device only monitors sensors that are enabled. Non-enabled sensors will be read as not touched (zero). The **Bitwise Sensor Select** byte can be multiple bytes depending on the amount of sensors contained on an IC.

For example, a 6 input IC requires 1 byte, a 15 input IC requires 2 bytes to be transmitted.

Bitwise Sensor Select Byte:

- Bitwise mask of which sensors are enabled and monitored (0 = not enabled, 1 = enabled)

Write Enabled Sensors Example:			Master	Slave
Byte 1	0xB0	Device Address		
Byte 2	0x0A	Command		
Byte 3	0xFF	Enable Sensors 0-7		
Byte 4	0x1F	Enable Sensors 8-12		
Byte 5	0x28	Write Checksum		

Notes:

- The checksum calculation for all "Write" commands is an 8-bit addition of all bytes transmitted after the device address byte.
- All Write commands place the device in the "Initializing" state for T_{init} . No other Write commands can be sent to the device while initializing.

Write TRZ

Command Structure

Byte 1		
S	0xB0 (Address)	A/N
Byte 2		
	0x0E (Command)	A/N
Byte 3		
	Sensor Start #	A/N
Byte 4		
	Sensor Count	A/N
Byte 5		
	Sensor n TRZ Multiplier Low Byte	A/N
Byte 6		
	Sensor n TRZ Multiplier High Byte	A/N
Byte 7		
	Sensor n TRZ Divider Low Byte	A/N
Byte 8		
	Sensor n TRZ Divider High Byte	A/N
Byte 9		
	Sensor n TRZ Zone Low Byte	A/N
Byte 10		
	Sensor n TRZ Zone High Byte	A/N
Byte = 4 +(nSensors * 6) + 1		
	Write Checksum	A/N
		P

Command Description

This command sets the TRZ's of **Sensor Count** consecutive sensors starting with **Sensor Start #**. In order to set all TRZ's to the same value, set **Sensor Start #** to 0xFF and **Sensor Count** to 0x01. In order to set multiple TRZ's to unique values, set **Sensor Count** and **Sensor Start #** appropriately, and send bytes 5-10 **Sensor Count** times with the respective TRZ values for each sensor.

Sensor Count Byte:

- The number of sensors to write

Sensor Start # Byte:

- The 0-based sensor number to start at for the write command

Write TRZ Example:				Master Out	Slave Out
Byte 1	0xB0	Address	Byte 10	0x00	Sensor 0 TRZ High
Byte 2	0x0E	Command	Byte 11	0x0D	Sensor 1 Multiplier Low
Byte 3	0x00	Start with Sensor 0	Byte 12	0x00	Sensor 1 Multiplier High
Byte 4	0x02	2 Sensors Enabled	Byte 13	0xE8	Sensor 1 Divider Low
Byte 5	0x0D	Sensor 0 Multiplier Low	Byte 14	0x03	Sensor 1 Divider High
Byte 6	0x00	Sensor 0 Multiplier High	Byte 15	0x60	Sensor 1 TRZ Low
Byte 7	0xE8	Sensor 0 Divider Low	Byte 16	0x00	Sensor 1 TRZ High
Byte 8	0x03	Sensor 0 Divider High	Byte 17	0xC0	Write Checksum
Byte 9	0x60	Sensor 0 TRZ Low			

Notes:

- The checksum calculation for all "Write" commands is an 8-bit addition of all bytes transmitted after the device address byte.
- All Write commands place the device in the "Initializing" state for T_{init} . No other Write commands can be sent to the device while initializing.

Write DVI Mode

Command Structure

Byte 1		
S	0xB0 (Address)	A/N
Byte 2		
	0x16 (Command)	A/N
Byte 3		
	DVI Mode Enable/Disable	A/N
Byte 4		
	Write Checksum	A/N
		P

Command Description

This command switches the device in and out of **DVI Mode**.

DVI Mode On/Off Byte:

- 0 = Disable DVI Mode
- !0 = Enable DVI Mode

Write DVI Mode Example:			Master Out	Slave Out
Byte 1	0xB0	Device Address		
Byte 2	0x16	Command		
Byte 3	0x01	Enable DVI Mode		
Byte 4	0x17	Write Checksum		

Notes:

- The checksum calculation for all “Write” commands is an 8-bit addition of all bytes transmitted after the device address byte.
- All Write commands place the device in the “Initializing” state for T_{init} . No other Write commands can be sent to the device while initializing.

Clear Device Errors

Command Structure

Byte 1		
S	0xB0 (Address)	A/N
Byte 2		
	0x1E (Command)	A/N
Byte 3		
	0xFF (Clear Errors Byte)	A/N
Byte 4		
	Write Checksum	A/N
		P

Command Description

This command is used for the sole purpose of **Clearing Device Errors**.

Note: the Clear Errors Byte value must be 0xFF.

Clear Device Errors Example:			Master	Slave
Byte 1	0xB0	Device Address		
Byte 2	0x1E	Command		
Byte 3	0xFF	Clear Errors Byte		
Byte 4	0x1D	Write Checksum		

Notes:

- The checksum calculation for all “Write” commands is an 8-bit addition of all bytes transmitted after the device address byte.
- All Write commands place the device in the “Initializing” state for T_{init} . No other Write commands can be sent to the device while initializing.

Reset Device

Command Structure

Byte 1		
S	0xB0 (Address)	A/N
Byte 2		
	0x52 (Command)	A/N
Byte 3		
	0x01 (Reset Device Byte)	A/N
Byte 4		
	Write Checksum	A/N
		P

Command Description

This command performs a soft **Reset** on the device.

Note: the Reset Device Byte value must be 0x01.

Reset Device Example:			Master	Slave
Byte 1	0xB0	Device Address		
Byte 2	0x52	Command		
Byte 3	0x01	Reset Device Byte		
Byte 4	0x53	Write Checksum		

Notes:

- The checksum calculation for all “Write” commands is an 8-bit addition of all bytes transmitted after the device address byte.
- All Write commands place the device in the “Initializing” state for T_{init} . No other Write commands can be sent to the device while initializing.

Write Latch-up Timeout

Command Structure

Byte 1		
S	0xB0 (Address)	A/N
Byte 2		
	0x0C (Command)	A/N
Byte 3		
	Latch-up Timeout Value	A/N
Byte 4		
	Write Checksum	A/N
		P

Command Description

This command is used to set the **Latch-up Timeout**.

Latch-up Timeout Value:

- 0 = Latch-up Timeout disabled
- 1–255 = Latch-up Timeout in seconds

Write Latch-up Timeout Example:

	Master	Slave
Byte 1	0xB0	Device Address
Byte 2	0x0C	Command
Byte 3	0x0A	Set 10 Second Timeout
Byte 4	0x16	Write Checksum

Notes:

- The checksum calculation for all “Write” commands is an 8-bit addition of all bytes transmitted after the device address byte.
- All Write commands place the device in the “Initializing” state for T_{init} . No other Write commands can be sent to the device while initializing.

Write Process Interval

Command Structure

Byte 1		
S	0xB0 (Address)	A/N
Byte 2		
	0x41 (Command)	A/N
Byte 3		
	Process Interval Value Low Byte	A/N
Byte 4		
	Process Interval Value High Byte	A/N
Byte 5		
	Write Checksum	A/N
		P

Command Description

This command is used to set the length of the **Process Interval**. Value is in microseconds and can be between 1000 and 50000.

Write Process Interval Example:			Master Out	Slave Out
Byte 1	0xB0	Device Address		
Byte 2	0x41	Command		
Byte 3	0x10	Set for 10 Milliseconds (Low)		
Byte 4	0x27	Set for 10 Milliseconds (High)		
Byte 5	0x78	Write Checksum		

Notes:

- The checksum calculation for all “Write” commands is an 8-bit addition of all bytes transmitted after the device address byte.
- All Write commands place the device in the “Initializing” state for T_{init} . No other Write commands can be sent to the device while initializing.

Write Number of Sample Sets

Command Structure

Byte 1		
S	0xB0 (Address)	A/N
Byte 2		
	0x43 (Command)	A/N
Byte 3		
	Sample Sets Value Low Byte	A/N
Byte 4		
	Sample Sets Value High Byte	A/N
Byte 5		
	Write Checksum	A/N
		P

Command Description

This command is used to set the **Number of Sample Sets**. For proper operation, value must be between one and a calculated maximum produced by HSS Touch Studio.

Note: values over the maximum possible in the Process Interval will result in undefined behavior.

Write Number of Sample Sets Example:			Master Out	Slave Out
Byte 1	0xB0	Device Address		
Byte 2	0x43	Command		
Byte 3	0x1E	Set for 30 Samples Low Byte		
Byte 4	0x00	Set for 30 Samples High Byte		
Byte 5	0x61	Write Checksum		

Notes:

- The checksum calculation for all “Write” commands is an 8-bit addition of all bytes transmitted after the device address byte.
- All Write commands place the device in the “Initializing” state for T_{init} . No other Write commands can be sent to the device while initializing.

Write Pulse Configuration

Command Structure

Byte 1		
S	0xB0 (Address)	A/N
Byte 2		
	0x44 (Command)	A/N
Byte 3		
	Pulse Count	A/N
Byte 4		
	Pulse Period Low Byte	A/N
Byte 5		
	Duty Cycle Selection(7:6), Pulse Period Highest 6 bits(5:0)	A/N
Byte 6		
	Write Checksum	A/N
		P

Command Description

Pulse Count, Pulse Period, and Duty Cycle are interrelated with the HSS Sample Sets and Process Interval values. These limits are calculated automatically by Touch Studio and should not be self adjusted.

Duty Cycle Bits:

- 0 = 25%
- 1 = 50%
- 2 = 75%

Write Pulse Configuration Example:			Master	Slave
Byte 1	0xB0	Device Address		
Byte 2	0x44	Command		
Byte 3	0x1E	30 Pulses		
Byte 4	0xE8	1000ns Pulse Period		
Byte 5	0x43	50% Duty Cycle		
Byte 6	0x8D	Write Checksum		

Notes:

- The checksum calculation for all "Write" commands is an 8-bit addition of all bytes transmitted after the device address byte.
- All Write commands place the device in the "Initializing" state for T_{init} . No other Write commands can be sent to the device while initializing.

Write Power Mode

Command Structure

Byte 1		
S	0xB0 (Address)	A/N
Byte 2		
	0x40 (Command)	A/N
Byte 3		
	Power Mode (7:4), Wake Mode (3:0)	A/N
Byte 4		
	Write Checksum	A/N
		P

Command Description

This command is used to select the **Power Mode** of the device as well as whether Wake Up Mode should wake up on a touch.

Note: the Wake Up Mode is not supported in HSS Robust products. Only Normal and Hibernate **Power Modes** are valid for HSS Robust products.

Power Mode Nibble Value:

- 0 = Hibernate
- 1 = Wake Up
- 2 = Normal

Wake Mode Nibble Value:

- 1 = Stays in Wake Up Mode
- 2 = Wakes Up Into Normal Mode

Write Power Mode Example:			Master Out	Slave Out
Byte 1	0xB0	Device Address		
Byte 2	0x40	Command		
Byte 3	0x22	Normal Mode, Wake Up		
Byte 4	0x62	Write Checksum		

Notes:

- The checksum calculation for all “Write” commands is an 8-bit addition of all bytes transmitted after the device address byte.
- All Write commands place the device in the “Initializing” state for T_{init} . No other Write commands can be sent to the device while initializing.

Write HSS Signature Configuration 1

Command Structure

Byte 1		
S	0xB0 (Address)	A/N
Byte 2		
	0x45 (Command)	A/N
Byte 3		
	Approach Count Min Value	A/N
Byte 4		
	Slow Level Off Count Min Value	A/N
Byte 5		
	Fast Level Off Count Min Value	A/N
Byte 6		
	No Touch Debounce Min Value	A/N
Byte 7		
	Write Checksum	A/N
		P

Command Description

This command is used to set the **Approach Count Min**, the **Slow Level Off Count Min**, the **Fast Level Off Count Min**, and the **No Touch Debounce Min** values.

Note: for a detailed description of bytes listed, please consult the HSS Training & Touch Studio videos included in HSS Development Kits.

Write HSS Signature Configuration 1 Example:

	Master Out	Slave Out
Byte 1	0xB0	Device Address
Byte 2	0x45	Command
Byte 3	0x03	Approach Count = 3
Byte 4	0x04	Slow Level Off Count = 4
Byte 5	0x03	Fast Level Off Count = 3
Byte 6	0x05	No Touch Debounce = 5
Byte 7	0x54	Write Checksum

Notes:

- The checksum calculation for all “Write” commands is an 8-bit addition of all bytes transmitted after the device address byte.
- All Write commands place the device in the “Initializing” state for T_{init} . No other Write commands can be sent to the device while initializing.

Write HSS Signature Configuration 2

Command Structure

Byte 1		
S	0xB0 (Address)	A/N
Byte 2		
	0x46 (Command)	A/N
Byte 3		
	Fast Touch dv/dt Percentage Value	A/N
Byte 4		
	Abort Touch Percentage Value	A/N
Byte 5		
	Abort Touch Count Max Value	A/N
Byte 6		
	Too Slow Count Max Value	A/N
Byte 7		
	Write Checksum	A/N
		P

Command Description

This command is used to set the **Fast Touch dv/dt Percentage**, the **Abort Touch Percentage**, the **Abort Touch Count Max**, and the **Too Slow Count Max**. For the percentage values, any value over 100 will result in undefined behavior.

Note: for a detailed description of bytes listed, please consult the HSS Training & Touch Studio videos included in HSS Development Kits.

Write HSS Signature Configuration 2 Example:			Master Out	Slave Out
Byte 1	0xB0	Device Address		
Byte 2	0x46	Command		
Byte 3	0x19	Fast Touch dv/dt % = 25		
Byte 4	0x19	Abort Touch % = 25		
Byte 5	0x02	Abort Touch Count Max = 2		
Byte 6	0x04	Too Slow Count Max = 4		
Byte 7	0x7E	Write Checksum		

Notes:

- The checksum calculation for all “Write” commands is an 8-bit addition of all bytes transmitted after the device address byte.
- All Write commands place the device in the “Initializing” state for T_{init} . No other Write commands can be sent to the device while initializing.

Write Sleep Time

Command Structure

Byte 1		
S	0xB0 (Address)	A/N
Byte 2		
	0x48 (Command)	A/N
Byte 3		
	One Time Sleep Value	A/N
Byte 4		
	Repeated Sleep Time	A/N
Byte 5		
	Checksum	A/N
		P

Command Description

This command is used to set the **Sleep Time** between samples and the sleep time after all samples are processed, during the process interval. Only values calculated by HSS Touch Studio for the current settings should be used for Sleep Time.

Note: this command is used only for HSS ELP products and not intended for use with Robust products. Using this command with HSS Robust products will result in undefined behavior.

Write Sleep Time Example:			Master	Slave
Byte 1	0xB0	Device Address		
Byte 2	0x48	Command		
Byte 3	0x01	Sleep Value		
Byte 4	0x18	Repeat Sleep Time		
Byte 5	0x61	Write Checksum		

Notes:

- The checksum calculation for all “Write” commands is an 8-bit addition of all bytes transmitted after the device address byte.
- All Write commands place the device in the “Initializing” state for T_{init} . No other Write commands can be sent to the device while initializing.

Write IRQ Enable

Command Structure

Byte 1		
S	0xB0 (Address)	A/N
Byte 2		
	0x4A (Command)	A/N
Byte 3		
	Write IRQ Enable Value	A/N
Byte 4		
	Write Checksum	A/N
		P

Command Description

This command sets the **IRQ Enable** state. If the IRQ is enabled, the IRQ line will operate as an active high interrupt and will go high whenever the touched state of an enabled sensor changes, and will be reset low when the sensor states are read. If the IRQ is not enabled, the IRQ line will be high only while a touch is present on an enabled sensor.

IRQ Enable Value Byte:

- 0 = IRQ not enabled
- !0 = IRQ enabled

Write IRQ Enable Example:			Master Out	Slave Out
Byte 1	0xB0	Device Address		
Byte 2	0x4A	Command		
Byte 3	0x01	Enable IRQ Operation		
Byte 4	0x4B	Write Checksum		

Notes:

- The checksum calculation for all "Write" commands is an 8-bit addition of all bytes transmitted after the device address byte.
- All Write commands place the device in the "Initializing" state for T_{init} . No other Write commands can be sent to the device while initializing.

Write I2C Address

Command Structure

Byte 1		
S	0xB0 (Address)	A/N
Byte 2		
	0x4B (Command)	A/N
Byte 3		
	New Address Value	A/N
Byte 4		
	Write Checksum	A/N
		P

Command Description

This command is used to set a unique **I2C Address** for the device for use when an I2C bus has multiple devices present.

Notes:

- Unless otherwise stated, the default I2C address for the HSS Touch IC is 0xB0
- Valid I2C addresses range from 0x10 to 0xEE

Write I2C Address Example:			Master	Slave
Byte 1	0xB0	Device Address		
Byte 2	0x4B	Command		
Byte 3	0xAA	Set IC address to 0xAA		
Byte 4	0xF5	Write Checksum		

Notes:

- The checksum calculation for all “Write” commands is an 8-bit addition of all bytes transmitted after the device address byte.
- All Write commands place the device in the “Initializing” state for T_{init} . No other Write commands can be sent to the device while initializing.

Read Device ID

Command Structure

Byte 1		
S	0xB0 (Address)	A/N
Byte 2		
	0x81 (Command)	A/N
Byte 3		
	Write Checksum	A/N
Byte 4		
RS	0xB1	A/N
Byte 5		
	Device Status	A/N
Byte 6		
	Return Byte Count (RBC)	A/N
Byte 7		
	Device ID Type Low Byte	A/N
Byte 8		
	Device ID Type High Byte	A/N
Byte 9		
	Device ID Version Low Byte	A/N
Byte 10		
	Device ID Version High Byte	A/N
Byte 11		
	Read Checksum	A/N
		P

Command Description

This command is used to read the **Device ID Type and Version**.

Device ID Type Word:

- Unique device identifier assigned by AlSentis, LLC.

Device ID Version Word:

- Unique device software version assigned by AlSentis, LLC.

Read Device ID Example:

				Master Out	Slave Out
Byte 1	0xB0	Address	Byte 7	0x0D	Device ID Low
Byte 2	0x81	Command	Byte 8	0x00	Device ID High
Byte 3	0x81	Write Checksum	Byte 9	0x01	Version Low
Byte 4	0xB1	Re-Start Command	Byte 10	0x00	Version High
Byte 5	0x01	Device Status (IC Ready)	Byte 11	0x13	Read Checksum
Byte 6	0x04	Return Byte Count			

Notes:

- The checksum calculation for all “Read” commands is an 8-bit addition of all bytes transmitted after the re-start byte.
- Device Status:
 - 1 = Ready and monitoring enabled sensors
 - 3 = Configuring
 - 4 = Initializing
 - 5 = Hibernating
 - 7 = DVI Mode

Read Enabled Sensors

Command Structure

Byte 1		
S	0xB0 (Address)	A/N
Byte 2		
	0x8A (Command)	A/N
Byte 3		
	Write Checksum	A/N
Byte 4		
RS	0xB1	A/N
Byte 5		
	Device Status	A/N
Byte 6		
	Return Byte Count (RBC)	A/N
Byte 7		
	Bitwise Sensor Select	A/N
Byte 8		
	Read Checksum	A/N
		P

Command Description

This command is used to read which sensors are **Enabled**. The **Return Byte Count** can be multiple bytes depending on the amount of sensors contained on an IC.

For example, a 6 input IC will return 1 byte, a 15 input IC will return 2 bytes.

Bitwise Sensor Select Byte:

- Bitwise mask of which sensors are enabled and monitored (0 = not enabled, 1 = enabled)

Read Enabled Sensors Example:			Master Out	Slave Out
Byte 1	0xB0	Address		
Byte 2	0x8A	Command		
Byte 3	0x8A	Write Checksum		
Byte 4	0xB1	Re-Start Command		
Byte 5	0x01	Device Status (IC Ready)		
Byte 6	0x02	Return Byte Count		
Byte 7	0xFF	Sensors 0-7 Enabled		
Byte 8	0x1F	Sensors 8-12 Enabled		
Byte 9	0x20	Read Checksum		

Notes:

- The checksum calculation for all "Read" commands is an 8-bit addition of all bytes transmitted after the re-start byte.
- Device Status:
 - 1 = Ready and monitoring enabled sensors
 - 3 = Configuring
 - 4 = Initializing
 - 5 = Hibernating
 - 7 = DVI Mode

Read TRZ

Command Structure

Byte 1	S	0xB0 (Address)	A/N
Byte 2		0x8E (Command)	A/N
Byte 3		Sensor Start #	A/N
Byte 4		Sensor Count	A/N
Byte 5		Write Checksum	A/N
Byte 6	RS	0xB1	A/N
Byte 7		Device Status	A/N
Byte 8		Return Byte Count (RBC)	A/N
Byte 9		Sensor n TRZ Multiplier Low Byte	A/N
Byte 10		Sensor n TRZ Multiplier High Byte	A/N
Byte 11		Sensor n TRZ Divider Low Byte	A/N
Byte 12		Sensor n TRZ Divider High Byte	A/N
Byte 13		Sensor n TRZ Zone Low Byte	A/N
Byte 14		Sensor n TRZ Zone High Byte	A/N
Byte = 8 + (nSensors * 6) + 1		Read Checksum	A/N
			P

Command Description

This command is used to Read the TRZ's of "Sensor Count" consecutive sensors starting with Sensor Start #. In order to read all of the TRZ's, set Sensor Start # to 0xFF and Sensor Count to 0x01. Bytes 9-14 will be repeated for each sensor read. Note: sensors will be read regardless of whether they are enabled or not.

Write TRZ Example:

			Master Out	Slave Out	
Byte 1	0xB0	Address	Byte 12	0x03	Sensor 3 Divider High
Byte 2	0x8E	Command	Byte 13	0x61	Sensor 3 TRZ Low
Byte 3	0x03	Start with Sensor 3	Byte 14	0x00	Sensor 3 TRZ High
Byte 4	0x01	Read 1 Sensor	Byte 15	0x94	Read Checksum
Byte 5	0x92	Write Checksum			
Byte 6	0xB1	Re-Start Command			
Byte 7	0x01	Device Status (IC Ready)			
Byte 8	0x06	Return Byte Count			
Byte 9	0x41	Sensor 3 Multiplier Low			
Byte 10	0x00	Sensor 3 Multiplier High			
Byte 11	0xE8	Sensor 3 Divider Low			

Sensor Count Byte:

- The number of sensors to read

Sensor Start # Byte:

- The 0-based sensor number to start at for the read command

Notes:

- The checksum calculation for all "Read" commands is an 8-bit addition of all bytes transmitted after the re-start byte.
- Device Status:
 - 1 = Ready and monitoring enabled sensors
 - 3 = Configuring
 - 4 = Initializing
 - 5 = Hibernating
 - 7 = DVI Mode

Read Device Status

Command Structure

Byte 1		
S	0xB0 (Address)	A/N
Byte 2		
	0x9E (Command)	A/N
Byte 3		
	Write Checksum	A/N
Byte 4		
RS	0xB1	A/N
Byte 5		
	Device Status	A/N
Byte 6		
	Return Byte Count (RBC)	A/N
Byte 7		
	Error Code	A/N
Byte 8		
	Read Checksum	A/N
		P

Command Description

This command is used to read the **Device's Status** and latest error.

Error Code:

- 0 = No error
- 1 = Checksum mismatch
- 2 = Unknown command
- 3 = Command format error (most likely too many bytes were sent for the given command)
- 4 = Command not allowed (device most likely is not in the correct state)

Read Device Status Example:			Master Out	Slave Out
Byte 1	0xB0	Address		
Byte 2	0x9E	Command		
Byte 3	0x9E	Write Checksum		
Byte 4	0xB1	Re-Start Command		
Byte 5	0x01	Device Status (IC Ready)		
Byte 6	0x02	Return Byte Count		
Byte 7	0x01	Status		
Byte 8	0x00	Error Code		
Byte 9	0x1C	Read Checksum		

Notes:

- The checksum calculation for all "Read" commands is an 8-bit addition of all bytes transmitted after the re-start byte.
- Device Status:
 - 1 = Ready and monitoring enabled sensors
 - 3 = Configuring
 - 4 = Initializing
 - 5 = Hibernating
 - 7 = DVI Mode

Read All Sensors

Command Structure

Byte 1		
S	0xB0 (Address)	A/N
Byte 2		
	0x9F (Command)	A/N
Byte 3		
	Write Checksum	A/N
Byte 4		
RS	0xB1	A/N
Byte 5		
	Device Status	A/N
Byte 6		
	Return Byte Count (RBC)	A/N
Byte 7		
	Sensor States	A/N
Byte 8		
	Read Checksum	A/N
		P

Command Description

This command is used to **Read** the touched status of all of the sensors.

Note: sensors that are not enabled will read as not touched.

Sensors States Mask Byte:

- Bitwise mask of which sensors are touched (0 = not touched, 1 = touched)

Read All Sensors Example:			Master Out	Slave Out
Byte 1	0xB0	Address		
Byte 2	0x9F	Command		
Byte 3	0x9F	Write Checksum		
Byte 4	0xB1	Re-Start Command		
Byte 5	0x01	Device Status (IC Ready)		
Byte 6	0x01	Return Byte Count		
Byte 7	0x20	Sensor 5 Touched		
Byte 8	0x22	Read Checksum		

Notes:

- The checksum calculation for all "Read" commands is an 8-bit addition of all bytes transmitted after the re-start byte.
- Device Status:
 - 1 = Ready and monitoring enabled sensors
 - 3 = Configuring
 - 4 = Initializing
 - 5 = Hibernating
 - 7 = DVI Mode

Read Latch-up Timeout

Command Structure

Byte 1		
S	0xB0 (Address)	A/N
Byte 2		
	0x8C (Command)	A/N
Byte 3		
	Write Checksum	A/N
Byte 4		
RS	0xB1	A/N
Byte 5		
	Device Status	A/N
Byte 6		
	Return Byte Count (RBC)	A/N
Byte 7		
	Latch-up Timeout Value	A/N
Byte 8		
	Read Checksum	A/N
		P

Command Description

This command is used to read the current **Latch-up Timeout** value.

Latch-up Timeout Value:

- 0 = Latch-up Timeout disabled
- 1–255 = Latch-up Timeout in seconds

Read Latch-up Timeout Example:			Master Out	Slave Out
Byte 1	0xB0	Address		
Byte 2	0x8C	Command		
Byte 3	0x8C	Write Checksum		
Byte 4	0xB1	Re-Start Command		
Byte 5	0x01	Device Status (IC Ready)		
Byte 6	0x01	Return Byte Count		
Byte 7	0x10	10 Second Timeout		
Byte 8	0x12	Read Checksum		

Notes:

- The checksum calculation for all “Read” commands is an 8-bit addition of all bytes transmitted after the re-start byte.
- Device Status:
 - 1 = Ready and monitoring enabled sensors
 - 3 = Configuring
 - 4 = Initializing
 - 5 = Hibernating
 - 7 = DVI Mode

Read Process Interval

Command Structure

Byte 1		
S	0xB0 (Address)	A/N
Byte 2		
	0xC1 (Command)	A/N
Byte 3		
	Write Checksum	A/N
Byte 4		
RS	0xB1	A/N
Byte 5		
	Device Status	A/N
Byte 6		
	Return Byte Count (RBC)	A/N
Byte 7		
	Process Interval Value Low Byte	A/N
Byte 8		
	Process Interval Value High Byte	A/N
Byte 9		
	Read Checksum	A/N
		P

Command Description

This command is used to read the current **Process Interval**. Value is in microseconds and can be between 1000 and 50000.

Read Process Interval Example:			Master Out	Slave Out
Byte 1	0xB0	Address		
Byte 2	0xC1	Command		
Byte 3	0xC1	Write Checksum		
Byte 4	0xB1	Re-Start Command		
Byte 5	0x01	Device Status (IC Ready)		
Byte 6	0x02	Return Byte Count		
Byte 7	0x10	10 Milliseconds (Low)		
Byte 8	0x27	10 Milliseconds (High)		
Byte 9	0x3A	Read Checksum		

Notes:

- The checksum calculation for all “Read” commands is an 8-bit addition of all bytes transmitted after the re-start byte.
- Device Status:
 - 1 = Ready and monitoring enabled sensors
 - 3 = Configuring
 - 4 = Initializing
 - 5 = Hibernating
 - 7 = DVI Mode

Read Number of Sample Sets

Command Structure

Byte 1		
S	0xB0 (Address)	A/N
Byte 2		
	0xC3 (Command)	A/N
Byte 3		
	Write Checksum	A/N
Byte 4		
RS	0xB1	A/N
Byte 5		
	Device Status	A/N
Byte 6		
	Return Byte Count (RBC)	A/N
Byte 7		
	Sample Sets Value Low Byte	A/N
Byte 8		
	Sample Sets Value High Byte	A/N
Byte 9		
	Read Checksum	A/N
		P

Command Description

This command is used to read the current **Number of Sample Sets**.

Read Number of Sample Sets Example:			Master Out	Slave Out
Byte 1	0xB0	Address		
Byte 2	0xC3	Command		
Byte 3	0xC3	Write Checksum		
Byte 4	0xB1	Re-Start Command		
Byte 5	0x01	Device Status (IC Ready)		
Byte 6	0x02	Return Byte Count		
Byte 7	0x1E	30 Samples Low Byte		
Byte 8	0x00	30 Samples High Byte		
Byte 9	0x21	Read Checksum		

Notes:

- The checksum calculation for all “Read” commands is an 8-bit addition of all bytes transmitted after the re-start byte.
- Device Status:
 - 1 = Ready and monitoring enabled sensors
 - 3 = Configuring
 - 4 = Initializing
 - 5 = Hibernating
 - 7 = DVI Mode

Read Pulse Configuration

Command Structure

Byte 1		
S	0xB0 (Address)	A/N
Byte 2		
	0xC4 (Command)	A/N
Byte 3		
	Write Checksum	A/N
Byte 4		
RS	0xB1	A/N
Byte 5		
	Device Status	A/N
Byte 6		
	Return Byte Count (RBC)	A/N
Byte 7		
	Pulse Count	A/N
Byte 8		
	Pulse Period Low Byte	A/N
Byte 9		
	Duty Cycle Selection(7:6), Pulse Period Highest 6 bits(5:0)	A/N
Byte 10		
	Read Checksum	A/N
		P

Command Description

This command is used to read the current **Pulse Count**, the **Pulse Period**, and the **Pulse Duty Cycle**.

Duty Cycle Bits:

- 0 = 25%
- 1 = 50%
- 2 = 75%

Read Pulse Configuration Example:			Master	Slave
Byte 1	0xB0	Address		
Byte 2	0xC4	Command		
Byte 3	0xC4	Write Checksum		
Byte 4	0xB1	Re-Start Command		
Byte 5	0x01	Device Status (IC Ready)		
Byte 6	0x03	Return Byte Count		
Byte 7	0x1E	30 Pulses		
Byte 8	0xE8	1000ns Pulse Period		
Byte 9	0x43	50% Duty Cycle		
Byte 10	0x4D	Read Checksum		

Notes:

- The checksum calculation for all “Read” commands is an 8-bit addition of all bytes transmitted after the re-start byte.
- Device Status:
 - 1 = Ready and monitoring enabled sensors
 - 3 = Configuring
 - 4 = Initializing
 - 5 = Hibernating
 - 7 = DVI Mode

Read Power Mode

Command Structure

Byte 1		
S	0xB0 (Address)	A/N
Byte 2		
	0xC0 (Command)	A/N
Byte 3		
	Write Checksum	A/N
Byte 4		
RS	0xB1	A/N
Byte 5		
	Device Status	A/N
Byte 6		
	Return Byte Count (RBC)	A/N
Byte 7		
	Power Mode (7:4), Wake Mode (3:0)	A/N
Byte 8		
	Read Checksum	A/N
		P

Command Description

This command is used to read the current **Power Mode** as well as whether **Wake Up Mode** is configured to wake on a touch.

Note: the Wake Up Mode is not supported in HSS Robust products. Only Normal and Hibernate **Power Modes** are valid for HSS Robust products.

Power Mode Nibble Value:

- 0 = Hibernate
- 1 = Wake up
- 2 = Normal

Wake Mode Nibble Value:

- 1 = Stays in Wake Up Mode
- 2 = Wakes Up Into Normal Mode

Read Power Mode Example:

	Master Out	Slave Out
Byte 1	0xB0	Address
Byte 2	0xC0	Command
Byte 3	0xC0	Write Checksum
Byte 4	0xB1	Re-Start Command
Byte 5	0x01	Device Status (IC Ready)
Byte 6	0x01	Return Byte Count
Byte 7	0x22	Normal Mode, Wake Up
Byte 8	0x24	Read Checksum

Notes:

- The checksum calculation for all “Read” commands is an 8-bit addition of all bytes transmitted after the re-start byte.
- Device Status:
 - 1 = Ready and monitoring enabled sensors
 - 3 = Configuring
 - 4 = Initializing
 - 5 = Hibernating
 - 7 = DVI Mode

Read HSS Signature Configuration 1

Command Structure

Byte 1		
S	0xB0 (Address)	A/N
Byte 2		
	0xC5 (Command)	A/N
Byte 3		
	Write Checksum	A/N
Byte 4		
RS	0xB1	A/N
Byte 5		
	Device Status	A/N
Byte 6		
	Return Byte Count (RBC)	A/N
Byte 7		
	Approach Count Min Value	A/N
Byte 8		
	Slow Level Off Count Min Value	A/N
Byte 9		
	Fast Level Off Count Min Value	A/N
Byte 10		
	No Touch Debounce Min Value	A/N
Byte 11		
	Read Checksum	A/N
		P

Command Description

This command is used to read the current **Approach Count Min**, **Slow Level Off Count Min**, **Fast Level Off Count Min**, and **No Touch Debounce Min** values.

Note: for a detailed description of bytes listed, please consult the HSS Training & Touch Studio videos included in HSS Development Kits.

Read HSS Signature Configuration 1 Example:			Master Out	Slave Out
Byte 1	0xB0	Address		
Byte 2	0xC5	Command		
Byte 3	0xC5	Write Checksum		
Byte 4	0xB1	Re-Start Command		
Byte 5	0x01	Device Status (IC Ready)		
Byte 6	0x04	Return Byte Count		
Byte 7	0x03	Approach Count = 3		
Byte 8	0x04	Slow Level Off Count = 4		
Byte 9	0x03	Fast Level Off Count = 3		
Byte 10	0x05	No Touch Debounce = 5		
Byte 11	0x14	Read Checksum		

Notes:

- The checksum calculation for all “Read” commands is an 8-bit addition of all bytes transmitted after the re-start byte.
- Device Status:
 - 1 = Ready and monitoring enabled sensors
 - 3 = Configuring
 - 4 = Initializing
 - 5 = Hibernating
 - 7 = DVI Mode

Read HSS Signature Configuration 2

Command Structure

Byte 1		
S	0xB0 (Address)	A/N
Byte 2		
	0xC6 (Command)	A/N
Byte 3		
	Write Checksum	A/N
Byte 4		
RS	0xB1	A/N
Byte 5		
	Device Status	A/N
Byte 6		
	Return Byte Count (RBC)	A/N
Byte 7		
	Fast Touch Percentage Value	A/N
Byte 8		
	Abort Touch Percentage Value	A/N
Byte 9		
	Abort Touch Count Max Value	A/N
Byte 10		
	Too Slow Count Max Value	A/N
Byte 11		
	Read Checksum	A/N
		P

Command Description

This command is used to read the **Fast Touch Percentage**, the **Abort Touch Percentage**, the **Abort Touch Count Max**, and the **Too Slow Count Max** values.

Note: for a detailed description of bytes listed, please consult the HSS Training & Touch Studio videos included in HSS Development Kits.

Read HSS Signature Configuration 2 Example:			Master Out	Slave Out
Byte 1	0xB0	Address		
Byte 2	0xC6	Command		
Byte 3	0xC6	Write Checksum		
Byte 4	0xB1	Re-Start Command		
Byte 5	0x01	Device Status (IC Ready)		
Byte 6	0x04	Return Byte Count		
Byte 7	0x19	Fast Touch dv/dt % = 25		
Byte 8	0x19	Abort Touch % = 25		
Byte 9	0x02	Abort Touch Count Max = 2		
Byte 10	0x04	Too Slow Count Max = 4		
Byte 11	0x3D	Read Checksum		

Notes:

- The checksum calculation for all “Read” commands is an 8-bit addition of all bytes transmitted after the re-start byte.
- Device Status:
 - 1 = Ready and monitoring enabled sensors
 - 3 = Configuring
 - 4 = Initializing
 - 5 = Hibernating
 - 7 = DVI Mode

Read DVI Value

Command Structure

Byte 1		
S	0xB0 (Address)	A/N
Byte 2		
	0xC7 (Command)	A/N
Byte 3		
	Sensor To Read	A/N
Byte 4		
	0x01	A/N
Byte 5		
	Write Checksum	A/N
Byte 6		
RS	0xB1	A/N
Byte 7		
	Device Status	A/N
Byte 8		
	Return Byte Count (RBC)	A/N
Byte 9		
	Value Low Byte	A/N
Byte 10		
	Value High Byte	A/N
Byte 11		
	Read Checksum	A/N
		P

Command Description

This command is used to read the **DVI Value** while the device is in DVI Mode.

Note: for Byte 4 value, any value other than 0x01 will result in undefined behavior.

Read DVI Value Example:			Master Out	Slave Out
Byte 1	0xB0	Address		
Byte 2	0xC7	Command		
Byte 3	0x03	Read Sensor 3		
Byte 4	0x01	Must Be 0x01		
Byte 5	0xC8	Write Checksum		
Byte 6	0xB1	Re-Start Command		
Byte 7	0x07	Device Status (IC Ready)		
Byte 8	0x02	Return Byte Count		
Byte 9	0x88	DVI Value Low for 136		
Byte 10	0x00	DVI Value High for 136		
Byte 11	0x91	Read Checksum		

Notes:

- The checksum calculation for all “Read” commands is an 8-bit addition of all bytes transmitted after the re-start byte.
- Device Status:
 - 1 = Ready and monitoring enabled sensors
 - 3 = Configuring
 - 4 = Initializing
 - 5 = Hibernating
 - 7 = DVI Mode

Read Sleep Time

Command Structure

Byte 1		
S	0xB0 (Address)	A/N
Byte 2		
	0xC8 (Command)	A/N
Byte 3		
	Write Checksum	A/N
Byte 4		
RS	0xB1	A/N
Byte 5		
	Device Status	A/N
Byte 6		
	Return Byte Count (RBC)	A/N
Byte 7		
	One Time Sleep Value	A/N
Byte 8		
	Repeated Sleep Time	A/N
Byte 9		
	Read Checksum	A/N
		P

Command Description

This command is used to read the current **Sleep Time** values.

Note: this command is used only for HSS ELP products and not intended for use with Robust products. Using this command with HSS Robust products will result in undefined behavior.

Read Sleep Time Example:			Master Out	Slave Out
Byte 1	0xB0	Address		
Byte 2	0xC8	Command		
Byte 3	0xC8	Write Checksum		
Byte 4	0xB1	Re-Start Command		
Byte 5	0x01	Device Status (IC Ready)		
Byte 6	0x02	Return Byte Count		
Byte 7	0x01	Sleep Value		
Byte 8	0x18	Repeat Sleep Time		
Byte 9	0x1C	Read Checksum		

Notes:

- The checksum calculation for all “Read” commands is an 8-bit addition of all bytes transmitted after the re-start byte.
- Device Status:
 - 1 = Ready and monitoring enabled sensors
 - 3 = Configuring
 - 4 = Initializing
 - 5 = Hibernating
 - 7 = DVI Mode

Read IRQ Enable

Command Structure

Byte 1		
S	0xB0 (Address)	A/N
Byte 2		
	0xCA (Command)	A/N
Byte 3		
	Write Checksum	A/N
Byte 4		
RS	0xB1	A/N
Byte 5		
	Device Status	A/N
Byte 6		
	Return Byte Count (RBC)	A/N
Byte 7		
	IRQ Enable Value	A/N
Byte 8		
	Read Checksum	A/N
		P

Command Description

This command is used to read the current **IRQ Enable** value.

IRQ Enable Value Byte:

- 0 = IRQ not enabled
- !0 = IRQ enabled

Read IRQ Enable Example:			Master Out	Slave Out
Byte 1	0xB0	Address		
Byte 2	0xCA	Command		
Byte 3	0xCA	Write Checksum		
Byte 4	0xB1	Re-Start Command		
Byte 5	0x01	Device Status (IC Ready)		
Byte 6	0x01	Return Byte Count		
Byte 7	0x01	Sensors 0 –6 Enabled		
Byte 8	0x03	Read Checksum		

Notes:

- The checksum calculation for all “Read” commands is an 8-bit addition of all bytes transmitted after the re-start byte.
- Device Status:
 - 1 = Ready and monitoring enabled sensors
 - 3 = Configuring
 - 4 = Initializing
 - 5 = Hibernating
 - 7 = DVI Mode

SSOP Package information

Typical 28-Lead Plastic Shrink Small Outline—5.3 mm Body [SSOP]

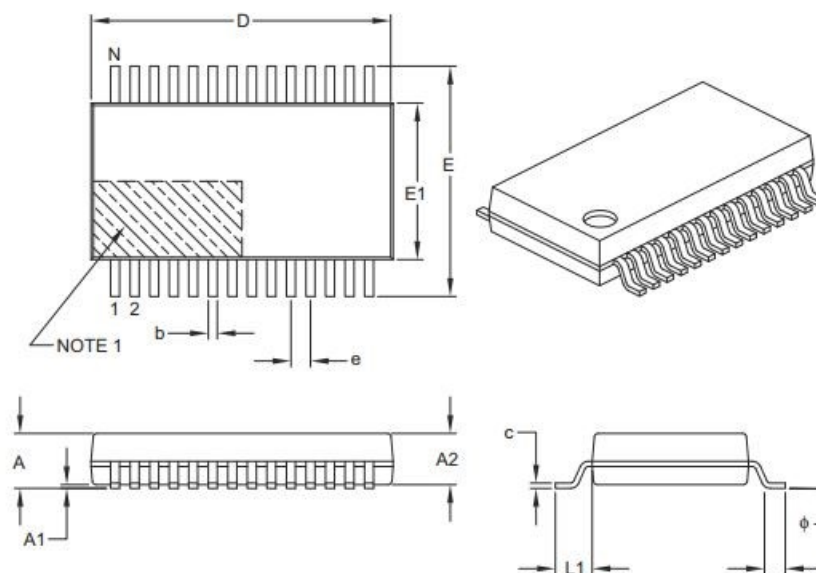

		Units	MILLIMETERS		
		Dimension Limits	MIN	NOM	MAX
Number of Pins	N		28		
Pitch	e		0.65 BSC		
Overall Height	A		–	–	2.00
Molded Package Thickness	A2		1.65	1.75	1.85
Standoff	A1		0.05	–	–
Overall Width	E		7.40	7.80	8.20
Molded Package Width	E1		5.00	5.30	5.60
Overall Length	D		9.90	10.20	10.50
Foot Length	L		0.55	0.75	0.95
Footprint	L1		1.25 REF		
Lead Thickness	c		0.09	–	0.25
Foot Angle	φ		0°	4°	8°
Lead Width	b		0.22	–	0.38

Notes:

- Pin 1 visual index feature may vary, but must be located within the hatched area.
- Dimensions D and E1 do not include mold flash or protrusions. Mold flash or protrusions shall not exceed 0.20 mm per side.
- Dimensioning and tolerancing per ASME Y14.5M.

BSC: Basic Dimension. Theoretically exact value shown without tolerances.

REF: Reference Dimension, usually without tolerance, for information purposes only.

SSOP Recommended Land Pattern

Typical 28-Lead Plastic Shrink Small Outline—5.3 mm Body [SSOP]

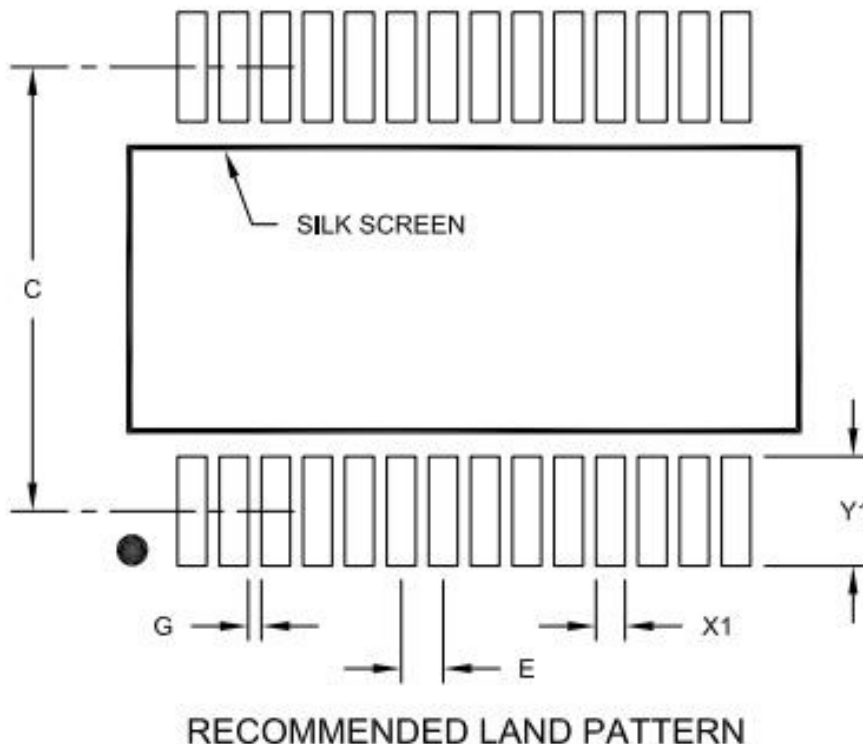

Dimension Limits	Units	MILLIMETERS		
		MIN	NOM	MAX
Contact Pitch	E	0.65 BSC		
Contact Pad Spacing	C		7.20	
Contact Pad Width (X28)	X1			0.45
Contact Pad Length (X28)	Y1			1.75
Distance Between Pads	G	0.20		

Notes:

1. Dimensioning and tolerancing per ASME Y14.5M

BSC: Basic Dimension. Theoretically exact value shown without tolerances.

SOIC Package Information

Typical 28-Lead Plastic Small Outline – Wide, 7.5 mm Body [SOIC]

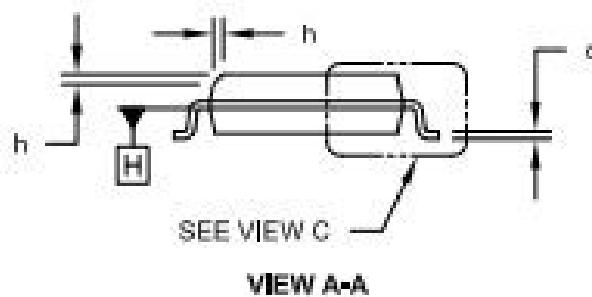
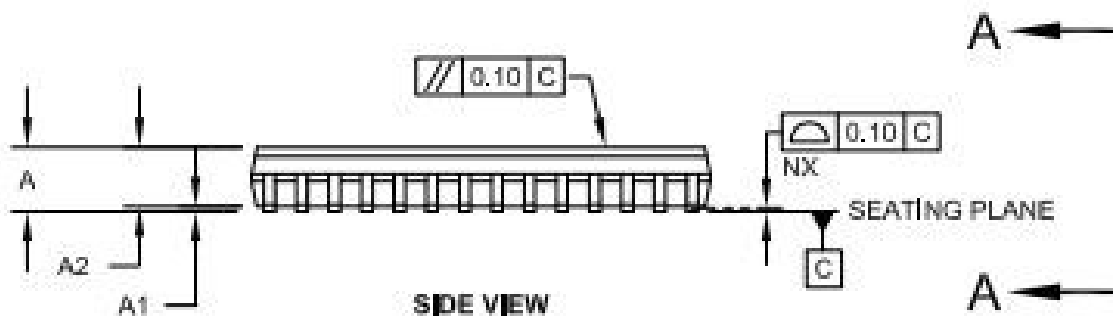
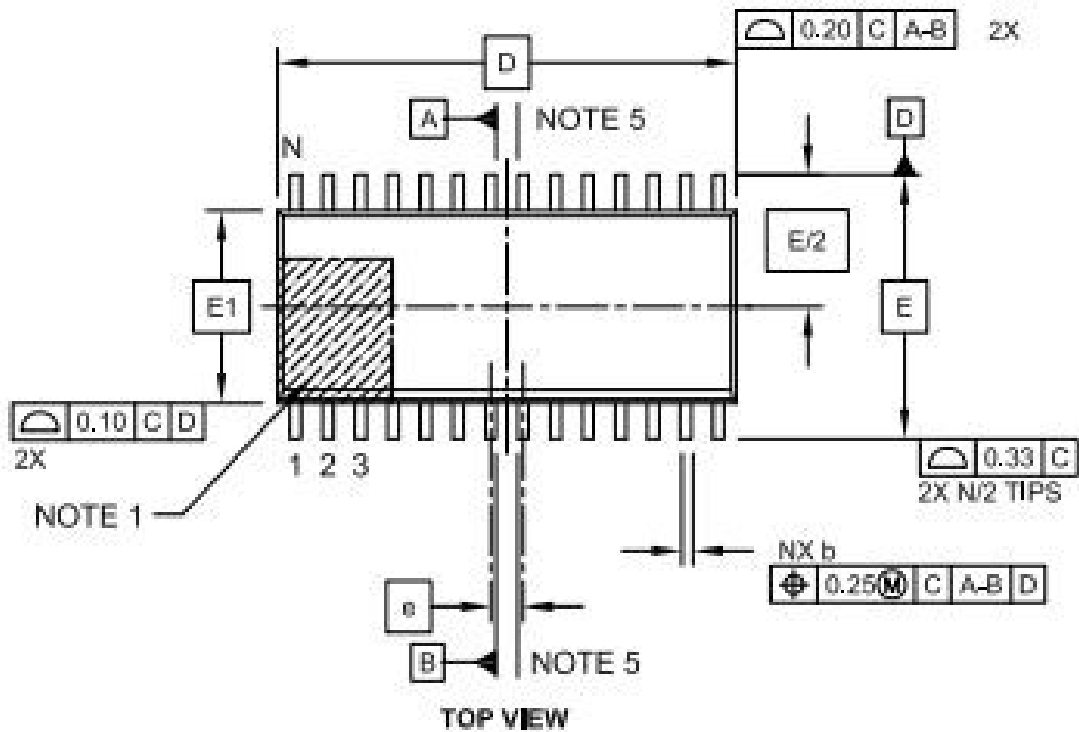

SOIC Package Information

Typical 28-Lead Plastic Small Outline – Wide, 7.5 mm Body [SOIC]

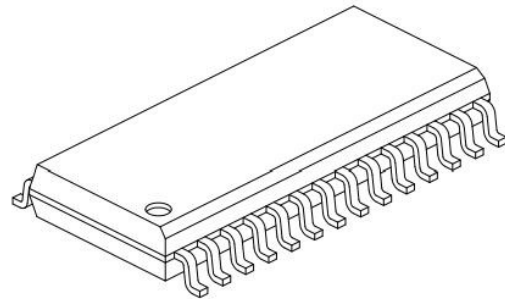
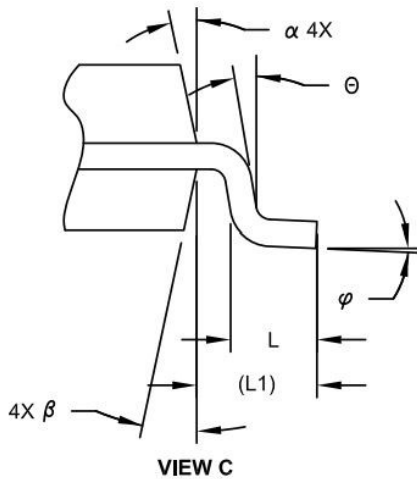

Dimension Limits	Units	MILLIMETERS		
		MIN	NOM	MAX
Number of Pins	N	28		
Pitch	e	1.27 BSC		
Overall Height	A	-	-	2.65
Molded Package Thickness	A2	2.05	-	-
Standoff §	A1	0.10	-	0.30
Overall Width	E	10.30 BSC		
Molded Package Width	E1	7.50 BSC		
Overall Length	D	17.90 BSC		
Chamfer (Optional)	h	0.25	-	0.75
Foot Length	L	0.40	-	1.27
Footprint	L1	1.40 REF		
Lead Angle	Θ	0°	-	-
Foot Angle	φ	0°	-	8°
Lead Thickness	c	0.18	-	0.33
Lead Width	b	0.31	-	0.51
Mold Draft Angle Top	α	5°	-	15°
Mold Draft Angle Bottom	β	5°	-	15°

Notes:

- Pin 1 visual index feature may vary, but must be located within the hatched area.
- § Significant Characteristic
- Dimension D does not include mold flash, protrusions or gate burrs, which shall not exceed 0.15 mm per end. Dimension E1 does not include interlead flash or protrusion, which shall not exceed 0.25 mm per side.
- Dimensioning and tolerancing per ASME Y14.5M
BSC: Basic Dimension. Theoretically exact value shown without tolerances.
REF: Reference Dimension, usually without tolerance, for information purposes only.
- Datums A & B to be determined at Datum H.

SOIC Recommended Land Pattern

Typical 28-Lead Plastic Small Outline – Wide, 7.5 mm Body [SOIC]

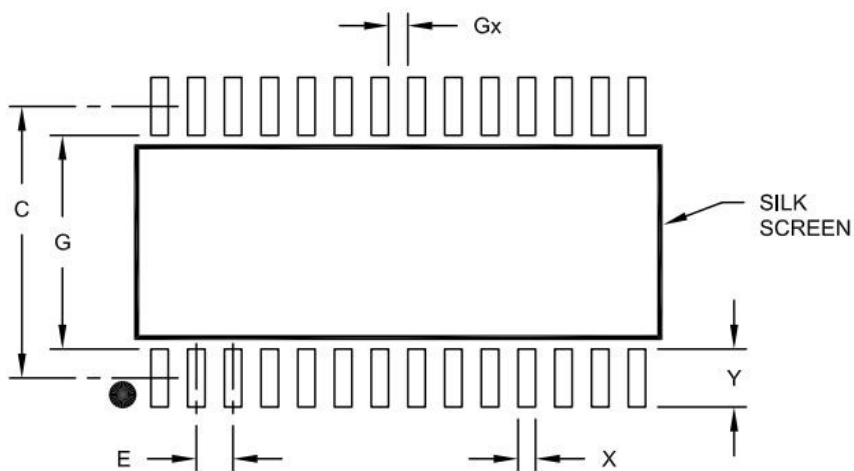

RECOMMENDED LAND PATTERN

Dimension Limits	Units	MILLIMETERS		
		MIN	NOM	MAX
Contact Pitch	E	1.27 BSC		
Contact Pad Spacing	C		9.40	
Contact Pad Width (X28)	X			0.60
Contact Pad Length (X28)	Y			2.00
Distance Between Pads	Gx	0.67		
Distance Between Pads	G	7.40		

Notes:

1. Dimensioning and tolerancing per ASME Y14.5M

BSC: Basic Dimension. Theoretically exact value shown without tolerances.

QFN Package Information

Typical 28-Lead Plastic Quad Flat, No Lead Package – 6x6x0.9 mm Body [QFN]

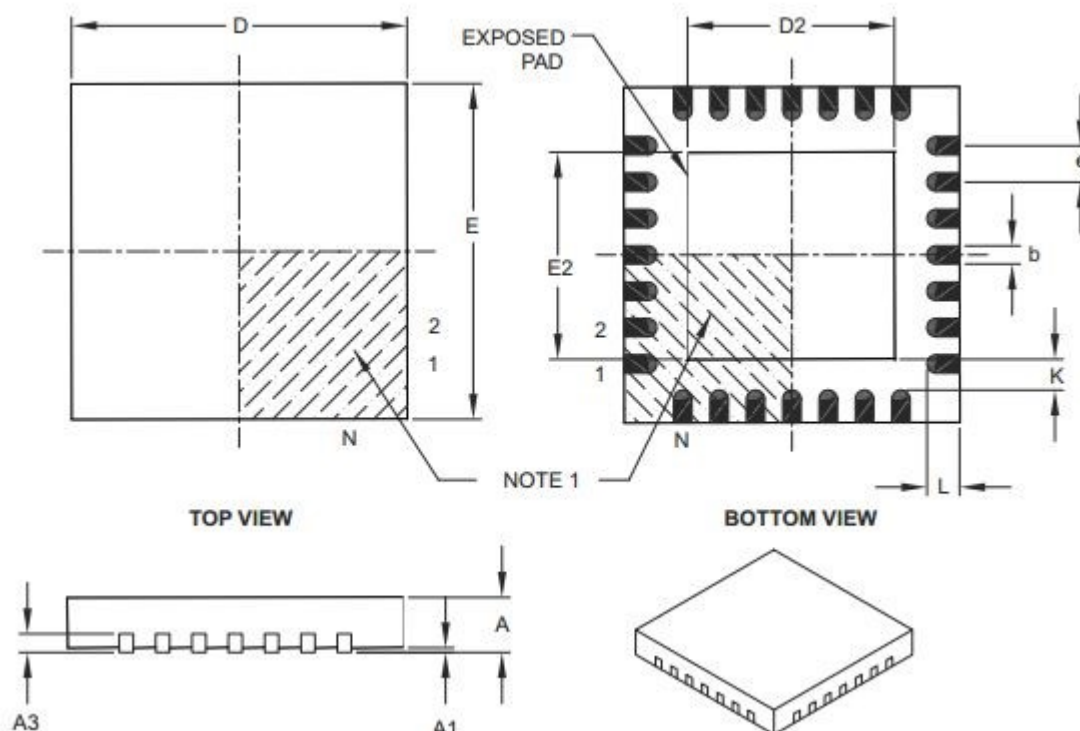

Dimension Limits	Units	MILLIMETERS		
		MIN	NOM	MAX
Number of Pins	N	28		
Pitch	e	0.65 BSC		
Overall Height	A	0.80	0.90	1.00
Standoff	A1	0.00	0.02	0.05
Contact Thickness	A3	0.20 REF		
Overall Width	E	6.00 BSC		
Exposed Pad Width	E2	3.65	3.70	4.20
Overall Length	D	6.00 BSC		
Exposed Pad Length	D2	3.65	3.70	4.20
Contact Width	b	0.23	0.30	0.35
Contact Length	L	0.50	0.55	0.70
Contact-to-Exposed Pad	K	0.20	-	-

Notes:

1. Pin 1 visual index feature may vary, but must be located within the hatched area.
2. Package is saw singulated.
3. Dimensioning and tolerancing per ASME Y14.5M.

BSC: Basic Dimension. Theoretically exact value shown without tolerances.

REF: Reference Dimension, usually without tolerance, for information purposes only.

QFN Recommended Land Pattern

Typical 28-Lead Plastic Quad Flat, No Lead Package – 6x6x0.9 mm Body [QFN]

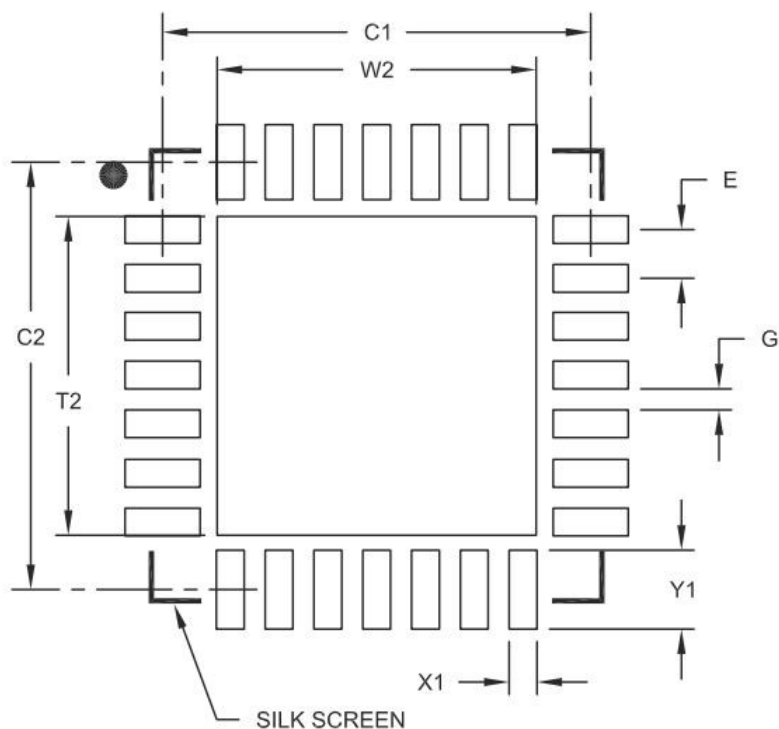

RECOMMENDED LAND PATTERN

Dimension Limits	Units	MILLIMETERS		
		MIN	NOM	MAX
Contact Pitch	E	0.65 BSC		
Optional Center Pad Width	W2			4.25
Optional Center Pad Length	T2			4.25
Contact Pad Spacing	C1		5.70	
Contact Pad Spacing	C2		5.70	
Contact Pad Width (X28)	X1			0.37
Contact Pad Length (X28)	Y1			1.00
Distance Between Pads	G	0.20		

Notes:

1. Dimensioning and tolerancing per ASME Y14.5M

BSC: Basic Dimension. Theoretically exact value shown without tolerances.

UQFN Package Information

Typical 28-Lead Plastic Ultra Thin Quad Flat, No Lead Package—4x4x0.5 mm Body [UQFN]

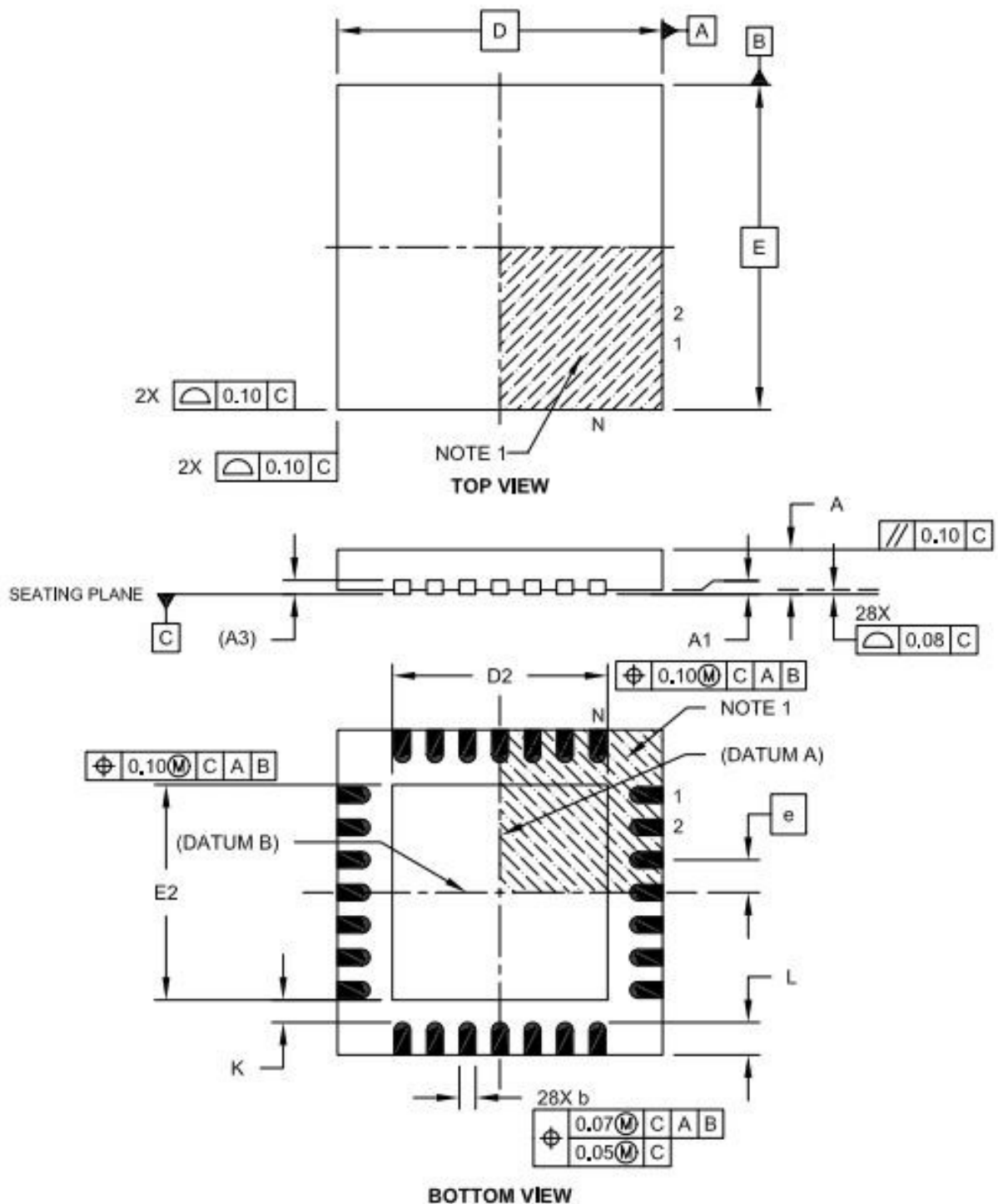

UQFN Package Information

Typical 28-Lead Plastic Ultra Thin Quad Flat, No Lead Package—4x4x0.5 mm Body [UQFN]

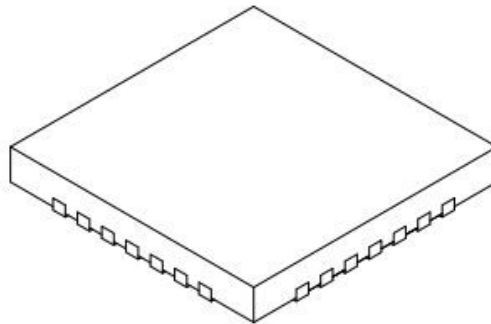

		Units	MILLIMETERS		
Dimension Limits			MIN	NOM	MAX
Number of Pins	N		28		
Pitch	e		0.40 BSC		
Overall Height	A	0.45	0.50	0.55	
Standoff	A1	0.00	0.02	0.05	
Contact Thickness	A3	0.127 REF			
Overall Width	E	4.00 BSC			
Exposed Pad Width	E2	2.55	2.65	2.75	
Overall Length	D	4.00 BSC			
Exposed Pad Length	D2	2.55	2.65	2.75	
Contact Width	b	0.15	0.20	0.25	
Contact Length	L	0.30	0.40	0.50	
Contact-to-Exposed Pad	K	0.20	-	-	

Notes:

- Pin 1 visual index feature may vary, but must be located within the hatched area.
- Package is saw singulated.
- Dimensioning and tolerancing per ASME Y14.5M.
 BSC: Basic Dimension. Theoretically exact value shown without tolerances.
 REF: Reference Dimension, usually without tolerance, for information purposes only.

UQFN Recommended Land Pattern

Typical 28-Lead Plastic Ultra Thin Quad Flat, No Lead Package – 4x4x0.5 mm Body [UQFN]

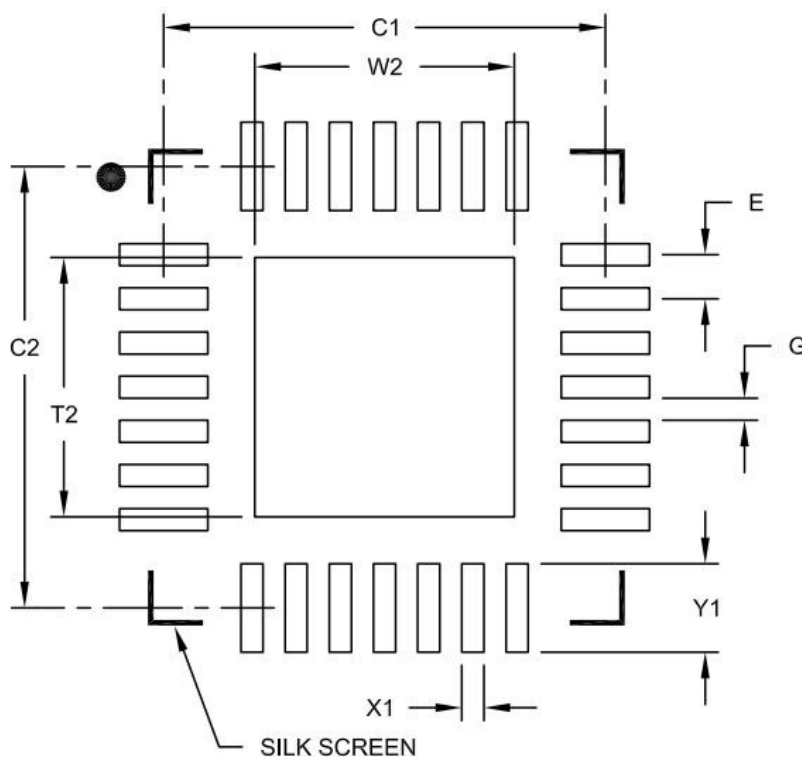

RECOMMENDED LAND PATTERN

Dimension Limits	Units	MILLIMETERS		
		MIN	NOM	MAX
Contact Pitch	E	0.40 BSC		
Optional Center Pad Width	W2			2.35
Optional Center Pad Length	T2			2.35
Contact Pad Spacing	C1		4.00	
Contact Pad Spacing	C2		4.00	
Contact Pad Width (X28)	X1			0.20
Contact Pad Length (X28)	Y1			0.80
Distance Between Pads	G	0.20		

Notes:

1. Dimensioning and tolerancing per ASME Y14.5M

BSC: Basic Dimension. Theoretically exact value shown without tolerances.

TO OUR VALUED CUSTOMERS

We are pleased to provide our valued customers with the most up to date and accurate documentation available to help ensure your success. If you have any questions regarding this documentation or the Alsentis HSS Technology, please contact us at alsentis.com.

Trademarks – Alsentis®, the Alsentis logo and HSS™ are trademarks of Alsentis, LLC..

Information contained in this publication regarding device applications and the like is provided only for your convenience and may be superseded by updates. It is your responsibility to ensure that your application meets with your specifications. ALSENTIS MAKES NO REPRESENTATIONS OR WARRANTIES OF ANY KIND WHETHER EXPRESS OR IMPLIED, WRITTEN OR ORAL, STATUTORY OR OTHERWISE, RELATED TO THE INFORMATION, INCLUDING BUT NOT LIMITED TO ITS CONDITION, QUALITY, PERFORMANCE, MERCHANTABILITY OR FITNESS FOR PURPOSE. Alsentis disclaims all liability arising from this information and its use. Use of Alsentis devices in life support and/or safety applications is entirely at the buyer's risk, and the buyer agrees to defend, indemnify and hold harmless Alsentis from any and all damages, claims, suits, or expenses resulting from such use. No licenses are conveyed, implicitly or otherwise, under any Alsentis intellectual property rights.